

The ES1433 Series electric strikes are designed to accommodate cylindrical locksets with up to 3/4" (19mm) latch throw. The strikes can be configured to fail-safe or fail-secure on site.

### Specifications

<b>Operating Voltage</b>	12 / 24VDC
<b>Current Draw</b>	300mA / 12VDC, 150mA / 24VDC
<b>Operating Temperature</b>	32°F to 120°F (0°C to 49°C)
<b>Humidity</b>	0% to 85% Non-condensing
<b>Latch Throw</b>	3/4"(19mm) [ 5/8"(16mm) strike depth, 1/8"(3mm) door gap ]
<b>Keeper Width</b>	1 7/16" (36mm)
<b>Static Strength</b>	1500 lbs (680Kg) (UL Witness test: 2000lbs)
<b>Dynamic Strength</b>	70 ft-lbs
<b>Endurance</b>	250,000 cycles (UL tested) 1,000,000 cycles (Factory tested)
<b>Performance Level</b>	Destructive Attack: Level I Line Security: Level I Standby Power: Level I Endurance: Level IV

Model	Latch Monitor	Body Construction
ES1433	-	Zinc Alloy

### UL Requirements

- For indoor use only.
- Wiring methods shall be in accordance with NFPA70.
- The ES1433 series is intended to be used with UL Listed Exit Hardware.
- The ES1433 series shall not impair the intended operation of an emergency exit.
- The ES1433 series shall not impair the operation of panic hardware mounted on the door.

### Fail-Safe / Fail-Secure Reversible

Change screw position at fail-safe / fail-secure hole to the desired setting.

#### Fail-Safe:

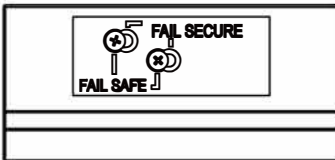

#### Fail-Secure:

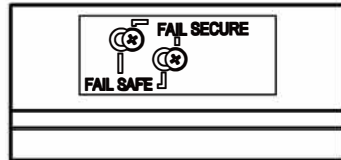

### ES1433 Series

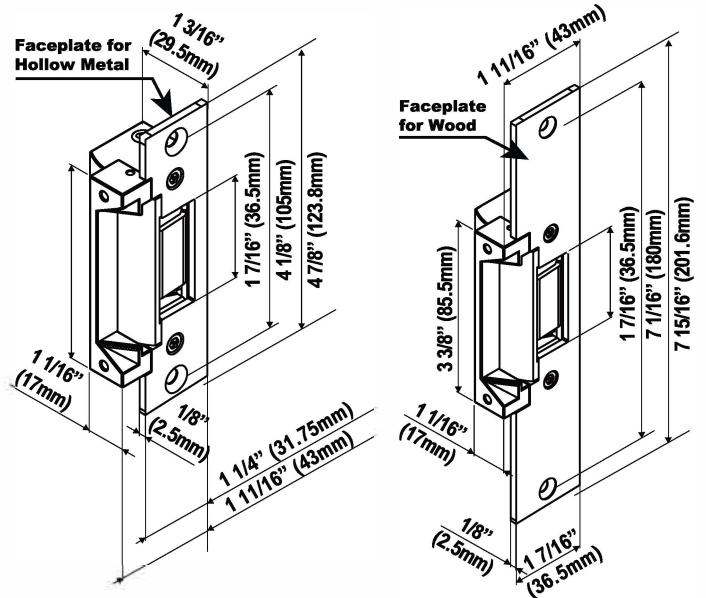

### Frame Application

#### Wood Frame Installation

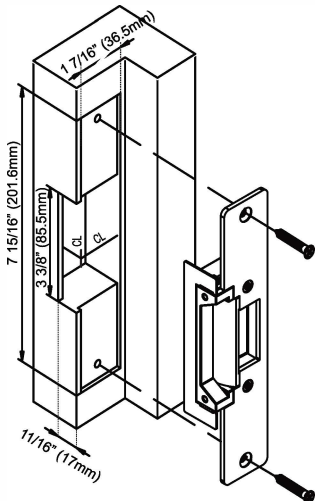

#### Hollow Metal Frame Installation

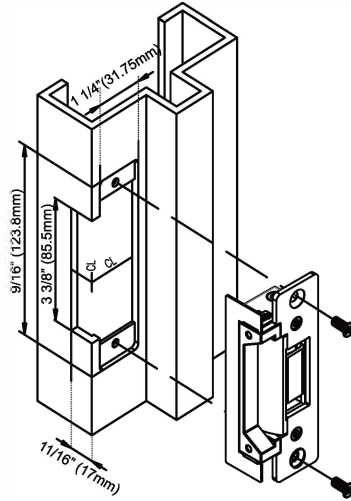

### Compatible Locksets

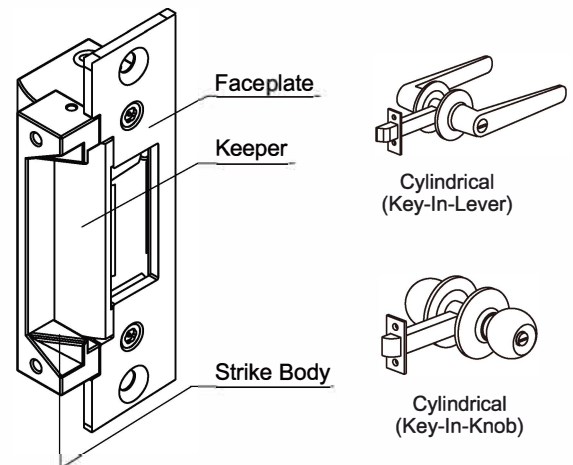

## Installation Instructions

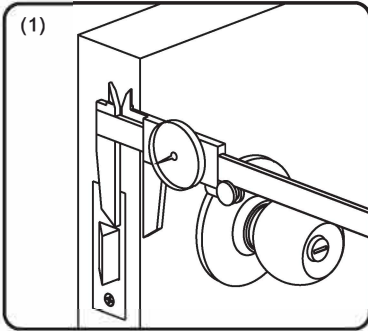

(1) Measure latch position.

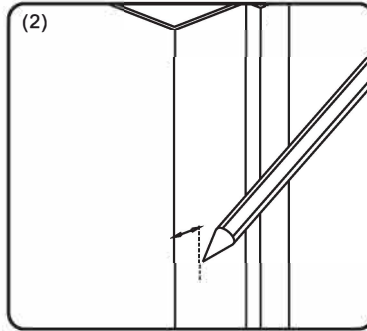

(2) Mark latch position line.

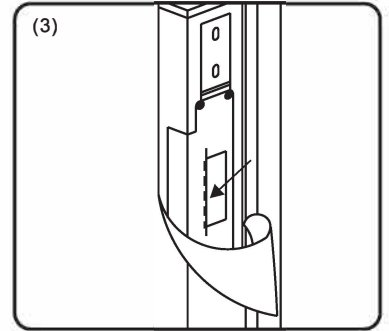

(3) Attach sticker template to marked centerline.

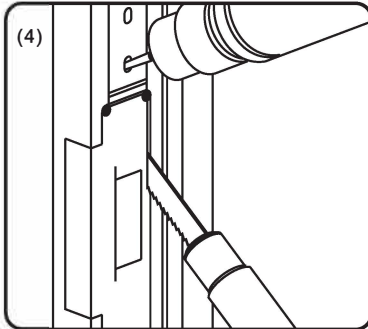

(4) Cut hole using template.

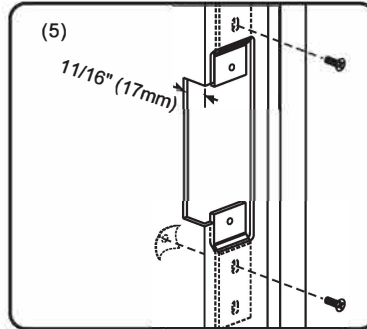

(5) Install the mounting tabs.

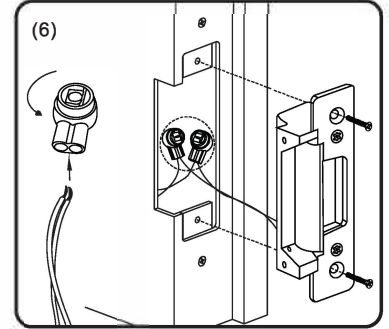

(6) Connect the wires using the crimp connectors, then test the strike, ensure to give it correct voltage.

### Caution:

Proper gap must be reserved between the strike keeper and latch bolt to prevent failure of solenoid valve.

### Using the Trim Plate

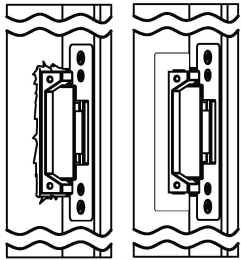

In case of over-cutting, use the enclosed trim plate to cover up any errors.

### Installing the Crimp Connectors:

Crimp connectors are provided to make wiring connections easier and more reliable. To install the connectors:

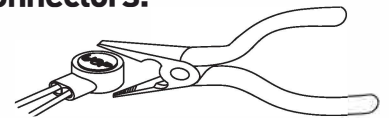

1. Insert the wires into the connector.
2. Use a crimping tool or pliers to evenly press down on the head of the connector.

### 12 / 24 VDC Plug-In Wiring

For 12VDC Operation:

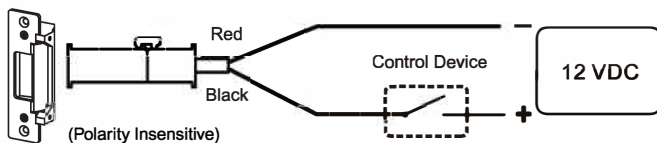

For 24VDC Operation:

