

CYLINDER REMOVAL AND REASSEMBLY

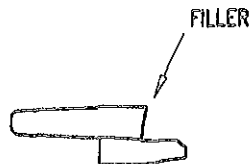
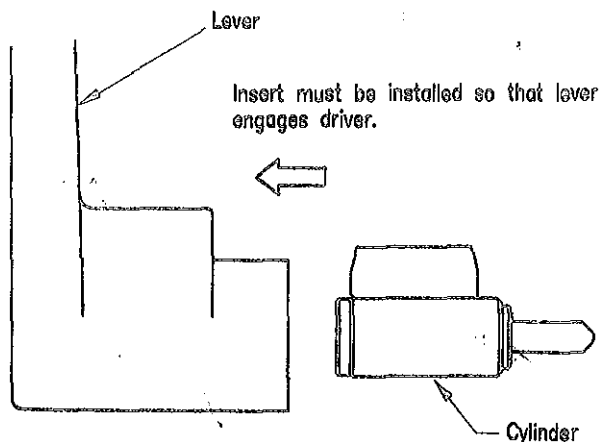

When re-keying or installing lock, be sure to engage the plastic lever locking insert.

INTERCHANGEABLE CORE

HOW TO REMOVE CORE

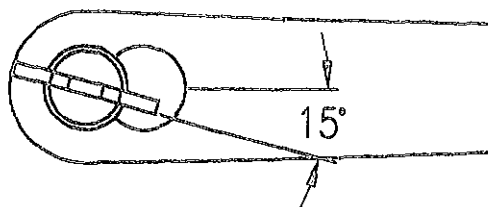

Insert control key and turn 15 degrees to the right until action stops. Pull on key to extract core.

HOW TO REPLACE CORE

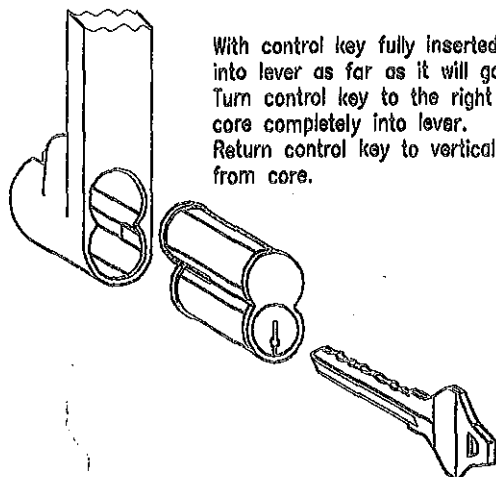

With control key fully inserted, push core into lever as far as it will go. Turn control key to the right and push core completely into lever. Return control key to vertical and remove from core.

CORE TAIL PIECE AND TAIL PIECE COVER APPLICATION

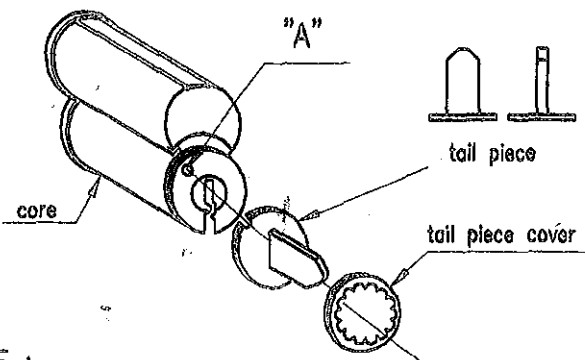

NOTE :

For function only use tail piece & tail piece cover. pushing "A" point, spln tail piece cover on the right as above picture.

DISASSEMBLE INTERCHANGEABLE LEVER

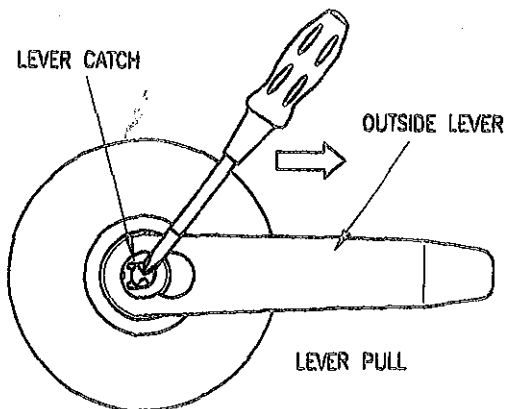

The outside Lever can be disassembled by pulling the outside Lever with pushing the Lever catch by driver through the hole on the outside Lever.

INSTRUCTIONS FOR INSTALLING HEAVY DUTY LEVER LOCK

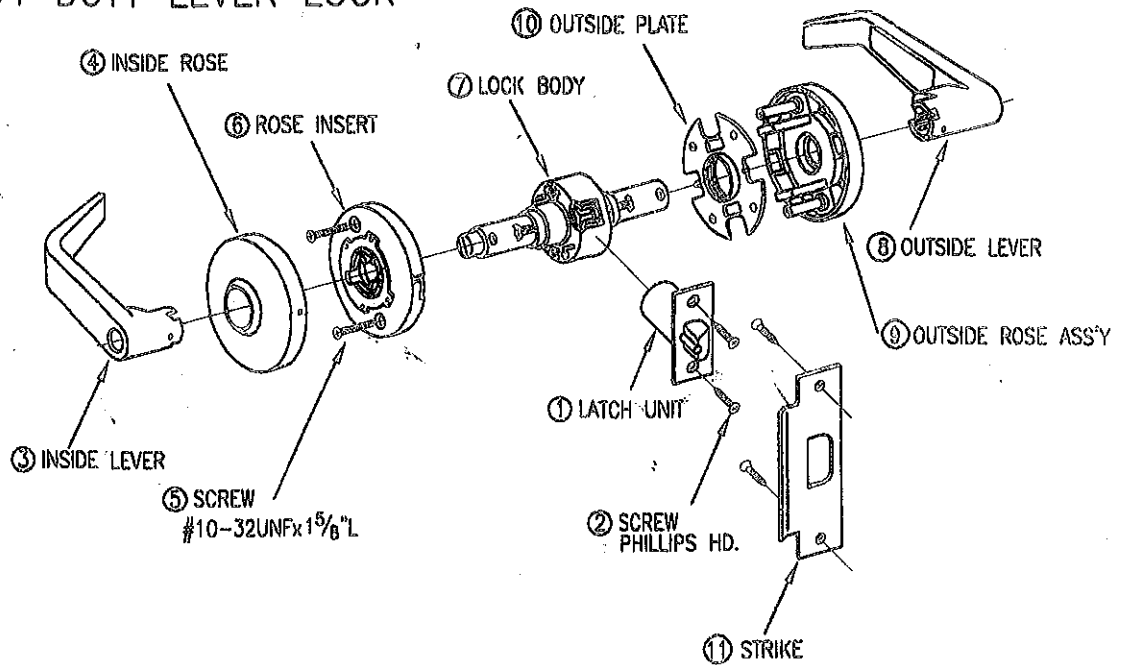

TOOLS REQUIRED	
PUSH PIN (PROVIDED)	
NO. 2 PHILLIPS SCREWDRIVER	
1/8-INCH DRILL BIT	
5/16-INCH DRILL BIT	

THIS LOCK IS FACTORY-PACKED FOR 1 3/4" THICK DOORS.

1. MARK DOOR

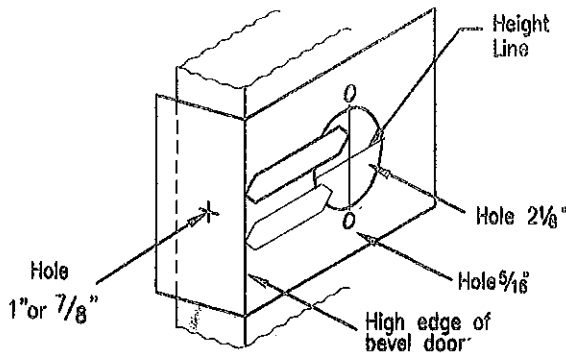

Mark height line on edge and face of door. Detach stub of template and mark center of door thickness on heightline. Fold template at proper marking for bevel of door (high or low bevel or flat). Position center line of template on height line. Hold in place and mark center point for 2 1/8" hole. And then the 1" or 7/8" hole. Also mark for 5/16" holes for mounting screws.

2. BORE HOLES

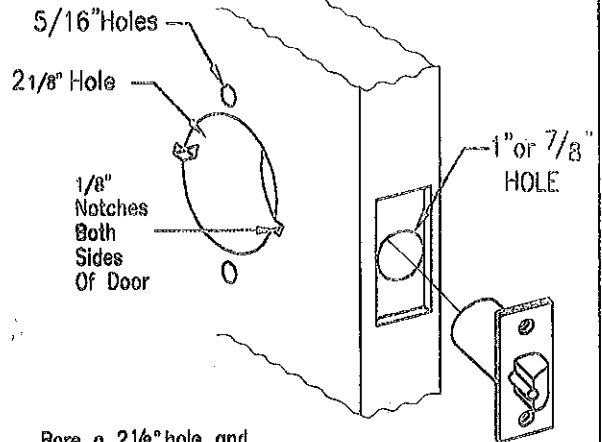

Bore a 2 1/8" hole and 5/16" holes. Bore holes from both sides of door to avoid splintering wood.

NOTE: We recommend using a drill guide to ensure straight holes. Bore a 1" or 7/8" hole straight into door edge to intersect with center of 2 1/8" hole. Use latch front faceplate to pattern for cutout. Front should fit flush with door edge. Install latch with screws provided.

(Wood door applications)
For proper alignment of lock chassis and lever, cut out notches for anchor plate lugs from both sides of door on horizontal height line. Mortise for anchor plates on both sides of door (see template).

NOTE: Width of notches should not exceed 1/8" for snug fit of anchors.

3. DISASSEMBLE INSIDE TRIM

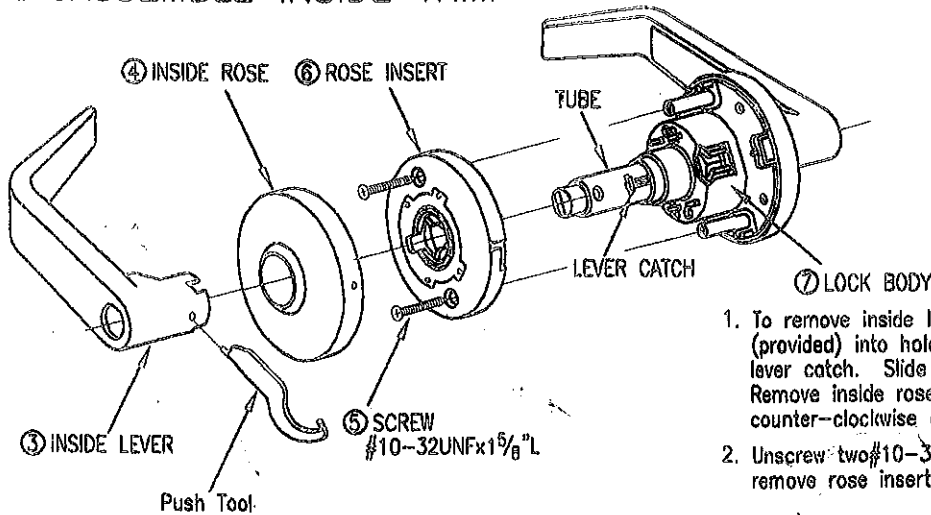

1. To remove inside lever ③. Insert push tool (provided) into hole on lever to depress the lever catch. Slide the lever from the tube. Remove inside rose ④ by slightly twisting counter-clockwise and pulling off.
2. Unscrew two #10-32UNFx1 5/8 L ⑤ screw and remove rose insert ⑥.

4. INSTALL OUTSIDE UNIT

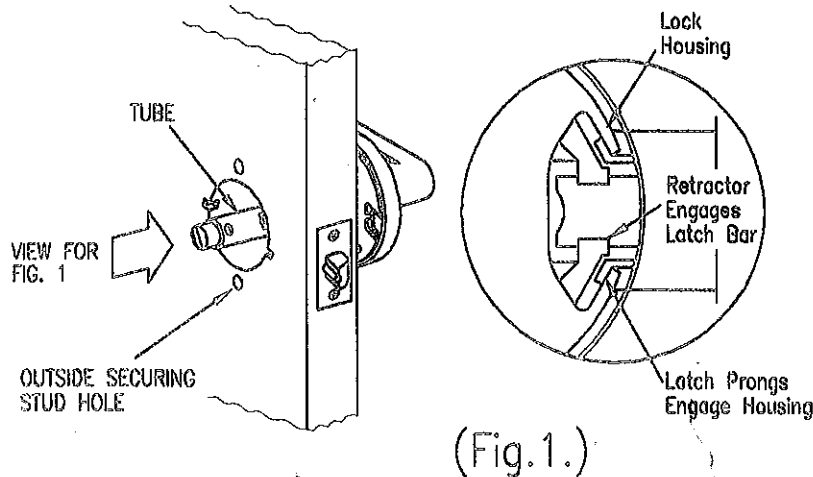

The lock body must engage the latch unit prongs as shown. The lock body retractor must engage the latch unit tail piece. Door must be open when installing lockset with guarded latch unit.

NOTE :

1. Be sure latch unit tail piece is centered about lock body retractor. Adjust it if necessary by outside plate.
2. For lock with outside securing stud type, slide two outside securing stud into prepared holes on door.

CAUTION:

DO NOT ATTEMPT TO MOUNT LOCK UNIT WITH DOOR CLOSED.

5. ASSEMBLE INSIDE TRIM

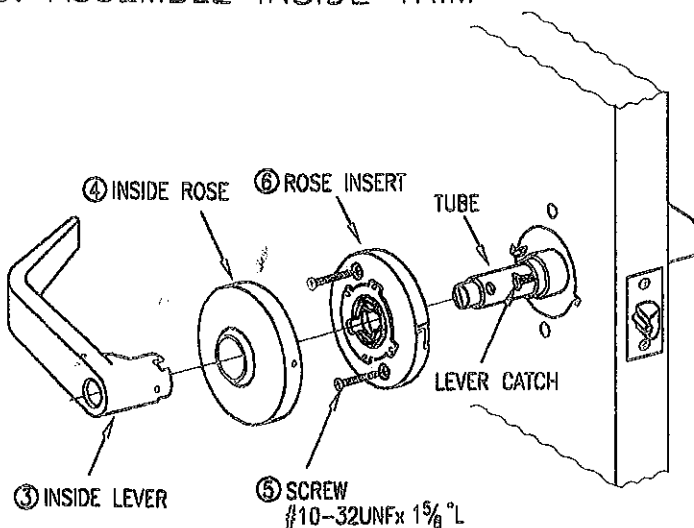

NOTE :

USE WHITE LONGER SCREWS FOR DOOR THICKER THAN 1-5/8".

1. Position the screw holes vertically with winder notch at inside diameter in line with lever catch. Then slide onto tube and align rose screw holes with #10-32UNFx1 5/8 L screw ⑤. (See note)
2. Place inside rose ④ onto inside rose insert ⑥ aligning two lances with recesses in rose insert ⑥ and turn clockwise to lock as firmly as possible
3. Slide inside lever ③ onto tube. Make certain lever catch on tube is engaged with lever.

6. INSTALL STRIKE

② SCREW PHILLIPS HD.

① STRIKE

When strike box is not used, recess in door jamb must be deep enough to allow latch bolt to extend to its full free length.

Deadlocking Plunger

Strike

Deadlocking plunger on latch bolt stops against strike, preventing forcing when door is closed.

7. ADJUST FOR DOOR THICKNESS

Disassemble the outside Lever (fig.2 or fig.3) and take off the outside Rose assembly. Adjust the door thickness by turning the outside plate ⑩ with hand.

APPROXIMATELY 1-1/2 TURNS BACKWARD FROM MAXIMUM TURN STOPPING POINT FOR 1-3/8" THICK DOOR.

ADJUST TO 3/8" FOR 1-3/4" THICKNESS OF DOOR

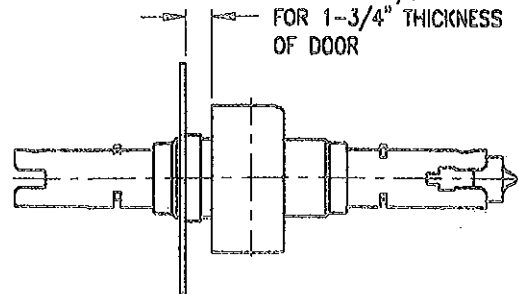
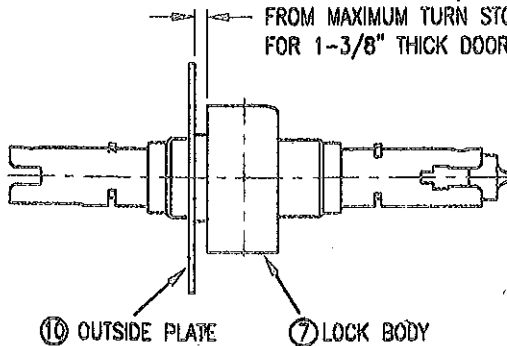

8. REMOVE OUTSIDE LEVER

③ LEVER PULL

② PUSH TOOL

① KEY TURN

(FIG.2)

Keyed locks:
Insert key into cylinder and using pointed end of spanner wrench, or similar tool, place into hole in lever. Turn key approximately 1/4 turn while exerting pressure on wrench until lever catch depresses. Pull off lever and driver.

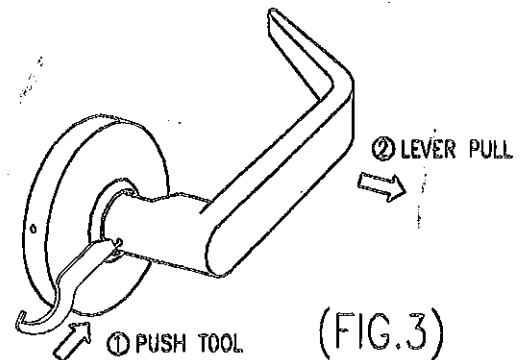

Non-keyed locks:
Place pointed end of spanner wrench, or similar tool, into hole in lever. Push in to depress lever catch and remove lever and driver.

INSTALLATION TEMPLATE

MARK
CENTER OF
DOOR
THICKNESS

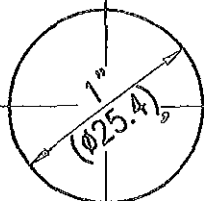

LATCH

HIGH BEVEL
LOW BEVEL

FLAT NO BEVEL

HIGH BEVEL
LOW BEVEL

2 3/4" BACKSET (70)

2 3/8" BACKSET (60)

2 1/8" DIA
(Ø54)

(Ø8)

5/16" HOLE

(Ø8)

5/16" HOLE

(3.0)

1/8"

(3.0)

1/8"

1 3/8"

(35)

1 3/8"

(35)

1 3/8"

(35)

1 3/8"

(35)

1 3/8"

(35)

1 3/8"

(35)

1 3/8"

(35)

1 3/8"

(35)

1 3/8"

(35)

1 3/8"

(35)

1 3/8"

(35)

1 3/8"

(35)

1 3/8"

(35)

1 3/8"

(35)

1 3/8"

(35)

1 3/8"

(35)

1 3/8"

(35)

1 3/8"

(35)

1 3/8"

(35)

1 3/8"

(35)

1 3/8"

(35)

1 3/8"

(35)

1 3/8"

(35)

1 3/8"

(35)

1 3/8"

(35)

1 3/8"

(35)

1 3/8"

(35)

1 3/8"

(35)

1 3/8"

(35)

1 3/8"

(35)

1 3/8"

(35)

1 3/8"

(35)

1 3/8"

(35)

1 3/8"

(35)

1 3/8"

(35)

1 3/8"

(35)

1 3/8"

(35)

1 3/8"

(35)

1 3/8"

(35)

1 3/8"

(35)

1 3/8"

(35)

1 3/8"

(35)

1 3/8"

(35)

1 3/8"

(35)

1 3/8"

(35)

1 3/8"

(35)

1 3/8"

(35)

1 3/8"

(35)

1 3/8"

(35)

1 3/8"

(35)

1 3/8"

(35)

1 3/8"

(35)

1 3/8"

(35)

1 3/8"

(35)

1 3/8"

(35)

1 3/8"

(35)

1 3/8"

(35)

1 3/8"

(35)

1 3/8"

(35)

1 3/8"

(35)

1 3/8"

(35)

1 3/8"

(35)

1 3/8"

(35)

1 3/8"

(35)

1 3/8"

(35)

1 3/8"

(35)

1 3/8"

(35)

1 3/8"

(35)

1 3/8"

(35)

1 3/8"

(35)

1 3/8"

(35)

1 3/8"

(35)

1 3/8"

(35)

1 3/8"

(35)

1 3/8"

(35)

1 3/8"

(35)

1 3/8"

(35)

1 3/8"

(35)

1 3/8"

(35)

1 3/8"

(35)

1 3/8"

(35)

1 3/8"

(35)

1 3/8"

(35)

1 3/8"

(35)

1 3/8"

(35)

1 3/8"

(35)

1 3/8"

(35)

1 3/8"

(35)

1 3/8"

(35)

1 3/8"

(35)

1 3/8"

(35)

1 3/8"

(35)

1 3/8"

(35)

1 3/8"

(35)

1 3/8"

(35)

1 3/8"

(35)

1 3/8"

(35)

1 3/8"

(35)

1 3/8"

(35)

1 3/8"

(35)

1 3/8"

(35)

1 3/8"

(35)

1 3/8"

(35)

1 3/8"

(35)

1 3/8"

(35)

1 3/8"

(35)

1 3/8"

(35)

1 3/8"

(35)

1 3/8"

(35)

1 3/8"

(35)

1 3/8"

(35)

1 3/8"

(35)

1 3/8"

(35)

1 3/8"

(35)

1 3/8"

(35)

1 3/8"

(35)

1 3/8"

(35)

1 3/8"

(35)

1 3/8"

(35)

1 3/8"

(35)

1 3/8"

(35)

1 3/8"

(35)

1 3/8"

(35)

1 3/8"

(35)

1 3/8"

(35)

1 3/8"

(35)

1 3/8"

(35)

1 3/8"

(35)

1 3/8"

(35)

1 3/8"

(35)

1 3/8"

(35)

1 3/8"

(35)

1 3/8"

(35)

1 3/8"

(35)

1 3/8"

(35)

1 3/8"

(35)

1 3/8"

(35)

1 3/8"

(35)

1 3/8"

(35)

1 3/8"

(35)

1 3/8"

(35)

1 3/8"

(35)

1 3/8"

(35)

1 3/8"

(35)

1 3/8"

(35)

1 3/8"

(35)

1 3/8"

(35)

1 3/8"

(35)

1 3/8"

(35)

1 3/8"

(35)

1 3/8"

(35)

1