

# INSTALLATION INSTRUCTION FOR 9900 SERIES PANIC EXIT DEVICE

## BEFORE INSTALLING DEVICE, PLEASE CHECK :

1. IF DOOR FITTED AND HUNG.
2. SIZE OF EXIT DEVICE, FUNCTION AND DESIGN.
  - 2.1. 36" DOORS, CAN BE CUT TO FIT DOORS DOWN TO 30" WIDE
  - 2.2. 48" DOORS, CAN BE CUT TO FIT DOORS DOWN TO 36" WIDE.
  - 2.3. HAND OF DEVICE AGAINST APPLICATION.

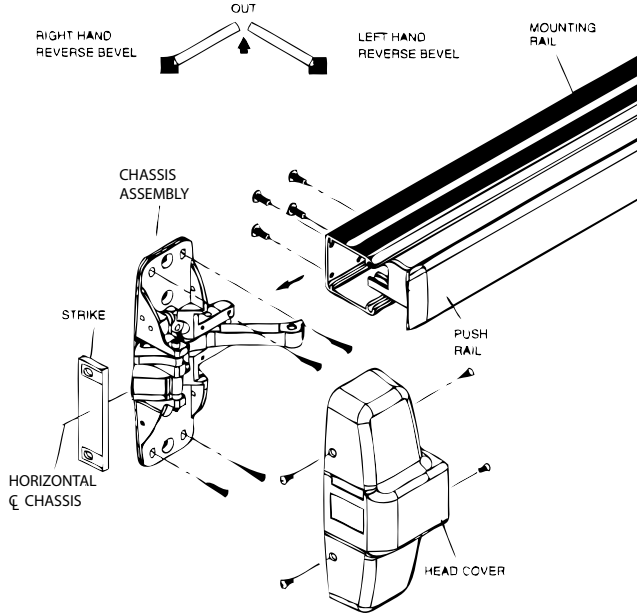

## 1. PREPARE DOOR

1. FOR 2-1/8" BORE PREP. POSITION TEMPLATE OVER EXISTING HOLE AND MARK FOR TWO CHASSIS MOUNTING SCREW HOLES

ENSURE VERTICAL  $\zeta$  CHASSIS PARALLEL TO DOOR EDGE

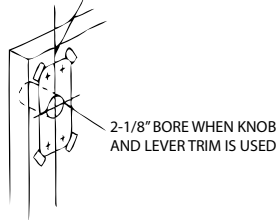

2. FOR DOOR W/O BORE PREP, MARK VERTICAL  $\zeta$  CHASSIS AND HORIZONTAL  $\zeta$  CHASSIS USING DIMENSIONS BELOW MOUNTING SCREW HOLES

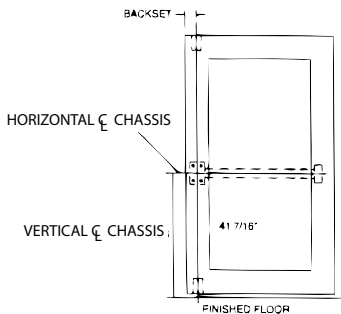

IDENTIFY TYPE OF INSTALLATION TO DETERMINE LOCATION OF VERTICAL  $\zeta$

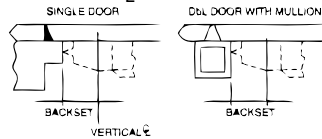

- STRIKE FOR BACKSET 2-1/4"
- STRIKE FOR BACKSET 1-1/2"
- STRIKE FOR BACKSET 1-3/4"
- STRIKE FOR BACKSET 2-1/4"

## 2. APPLY HARDWARE

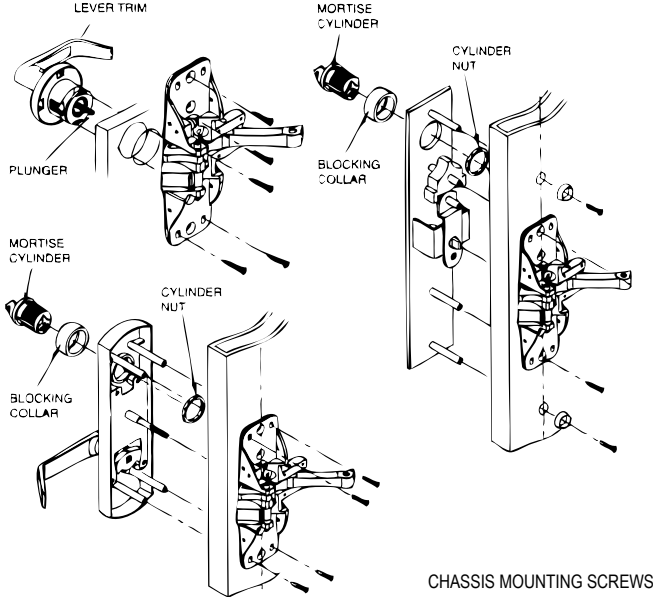

## 3. APPLY RAIL ASSEMBLY

1. CHECK THE SIZE OF DEVICE, IF CUTTING TO LENGTH IS REQUIRED.
2. DETERMINE CUT OFF LENGTH "X" BY SUBTRACTING 1-3/4" FROM "Y". MARK CUT OFF POINT ON MOUNTING RAIL.
3. DEPRESS ARM INTO RAIL OPENING AND SLIDE RAIL ONTO CHASSIS

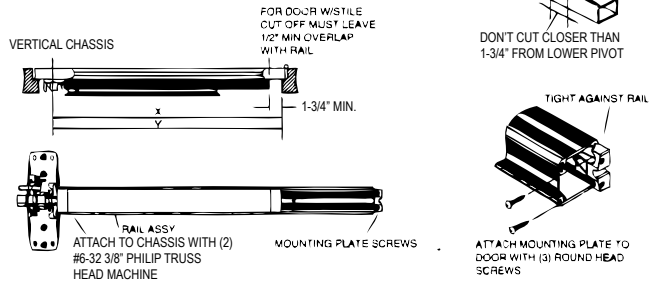

## 4. APPLY COVER AND STRIKES

