

Installation Instructions

CGN05 Locks

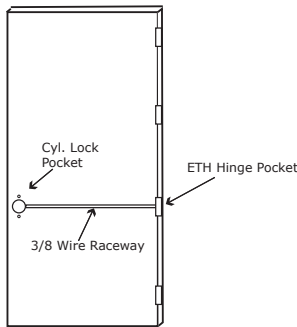

STEP 1: The door must be machined with a 3/8" wire raceway, cylindrical lock pocket & prepped for a energy transfer hinge. **Make sure the cylindrical pocket is free of debris.**



STEP 2: Run the wires from the ETH hinge through the 3/8" raceway starting at the ETH hinge & exiting into the lock pocket.

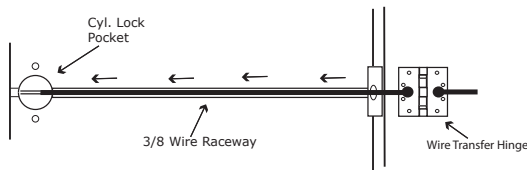

STEP 3: Screw the ETH hinge to the door. At this time **DO NOT** connect the hinge wires on the jamb side to the wires coming from the power supply.

STEP 4: Connect the wires exiting the lock pocket to the Power Transfer.

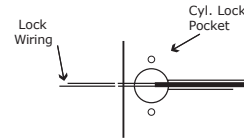

STEP 5 : Double check the wiring connection that been Terminated properly. The Cyl lock pocket to the main cylindrical wiring.

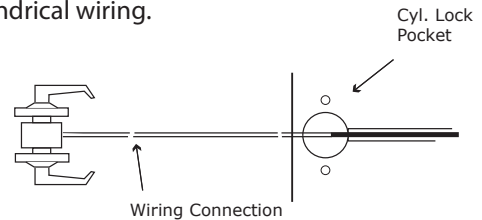

STEP 6: Carefully slip the connected cylindrical lock chassis into the lock pocket paying close attention not to pinch any wires.

STEP 7: Mount the cylindrical lock per manufacturer's instructions.

STEP 8: Connect the wires from the power supply at the ETH hinge on the jamb side. Connect the hinge to the jamb.

LEGEND OF TERMS

EU: (Fail Secure) When power is applied, the outside trim will unlock. When power is removed, the outside trim is locked.

EL: (Fail Safe) When power is applied, the outside trim will lock. When power is removed, the outside trim is unlocked.

REX: (Request to Exit Switch) Monitors the inside handle.

ELECTRICAL SPECIFICATIONS

SOLENOIDS:

VOLTS	CURRENT
24VAC/DC	0.38A
12VAC/DC	0.19A

SWITCHES: .25A 24VAC/DC

REX: White - Common (C)
Blue - Normally Open (NO)
Black - Normally Closed (NC)

EU (Fail Secure)

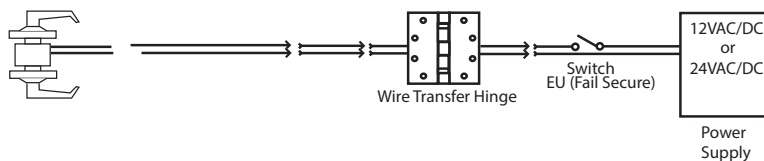

EL (Fail Safe)

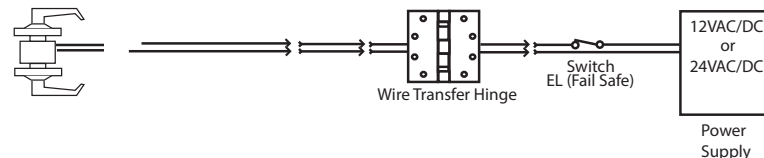

CAL-ROYAL Cylindrical Clutch Lock

Note: In changing the electrical operation of this solenoid you will need to remove the armature which is set into place with blue thread locker. The process is delicate because it is easy to loose parts and destroy the solenoid in the changing process. Please read the instructions before attempting to decide if this is an adventure you want to proceed with.

These instructions are to assist in changing the function of the solenoid in the CAL-ROYAL cylindrical lock. This process requires some basic hand tools and the dismantling of the lock chassis. It is recommended that you leave the outside of the lock assembled. Remove the in-side handle and spring cage. Remove the cotter pin; this pin holds the lock together. Slide the bell housing up and off the inside spindle. **Note:** there are 2 springs inside and they tend to shoot out, do not loose them. You will need to remove the solenoid from the inside assembly by removing the clip which would be inside the spindle. A small standard screwdriver will work; the clip would be at the far left of the picture bellow. Once you have the solenoid free from the assembly remove the clip at the far right of the picture bellow. This clip is made to be removed using your fingers. Pinch and remove this clip to disassemble the solenoid. Remove the armature

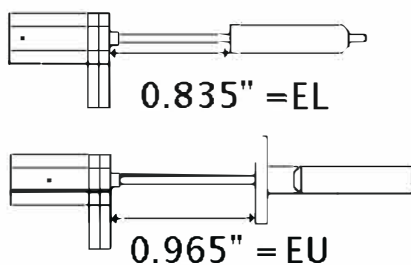
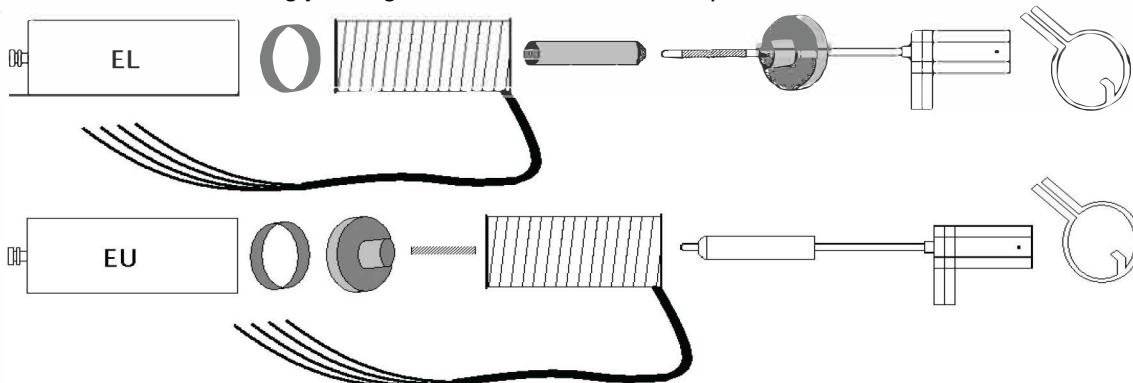

Re-thread the armature into its proper place for the desired electrical operation. Use the gauge included with the lock and these instructions to reset the solenoid for the needed electrical operation, gauge pictured bellow right. If this lock didn't come with a gauge you will need to use calipers to set the length, pictured left. Place the gauge between the head of the solenoid and the armature or armature seat as pictured to the left and thread the armature until everything is snug or the calipers read the proper distance. Reassemble the solenoid and place it back into the assembly and reassemble the lock. It is suggested that you bench test the lock before sending it in to the filed after performing this process.

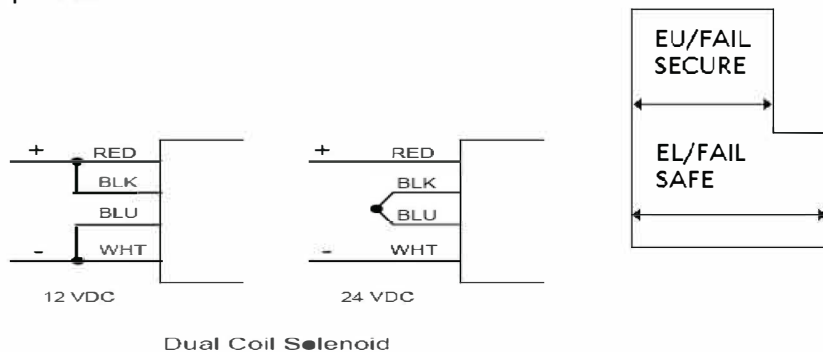

Legend:

EU - Fail Secure - Electrically Un-lock

EL - Fail Safe - Electrically lock

Template for CGN05 Cylindrical Locks

