

INSTALLATION INSTRUCTION FOR

#5000 SERIES FIRE EXIT DEVICE

BEFORE INSTALLING DEVICE, PLEASE CHECK :

1. IF DOOR FITTED AND HUNG.
2. SIZE OF EXIT DEVICE, FUNCTION AND DESIGN...
 - 2.1. 36" DOORS, CAN BE CUT TO FIT DOORS DOWN TO 30" WIDE.
 - 2.2. 48" DOORS, CAN BE CUT TO FIT DOORS DOWN TO 36" WIDE.
 - 2.3. HAND OF DEVICE AGAINST APPLICATION.

SURFACE OF DOOR FOR EXIT DEVICE APPLIED MUST BE FLUSHED.

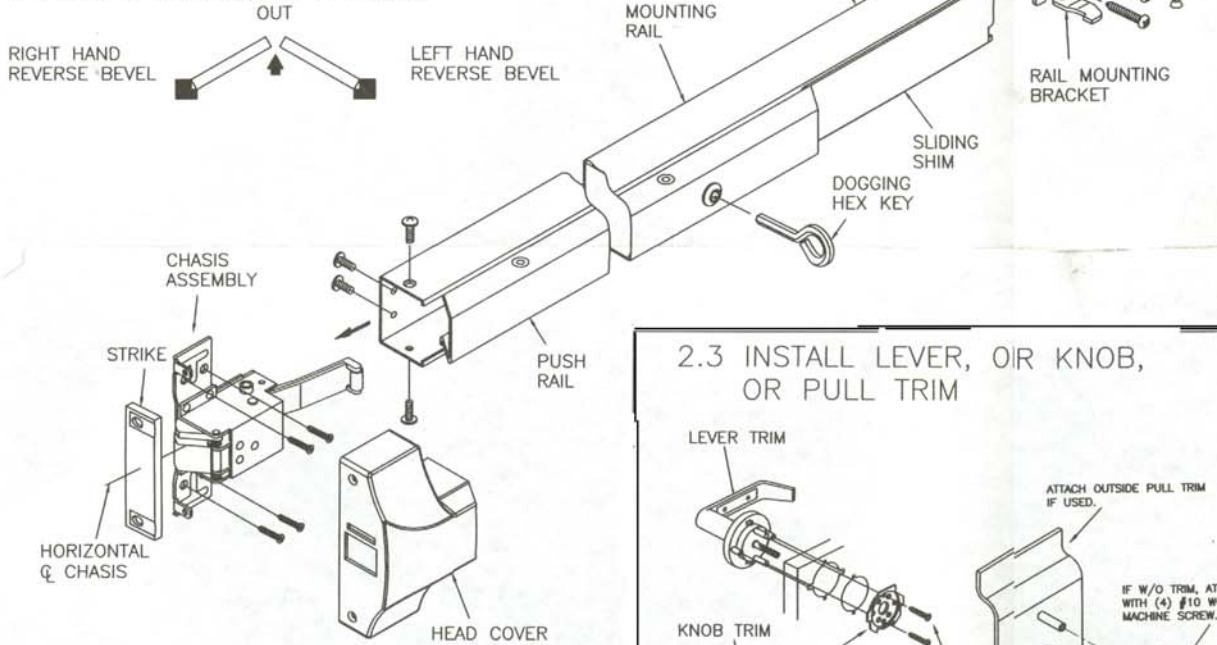

2.3 INSTALL LEVER, OR KNOB, OR PULL TRIM

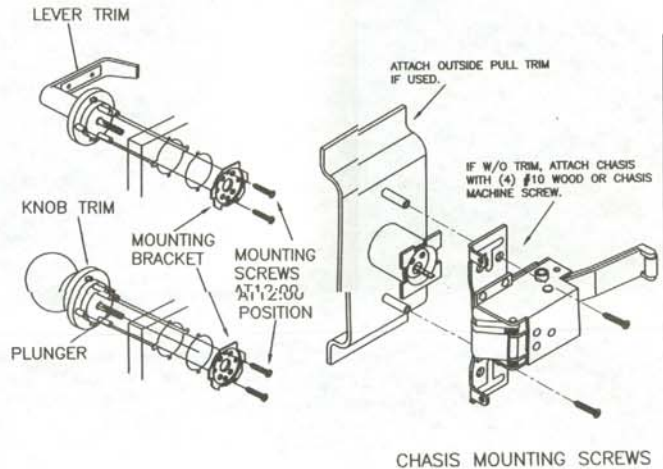

1. TYPE OF INSTALLATION

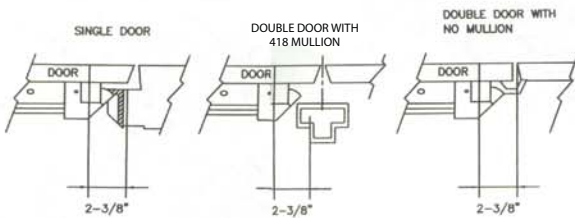

2. APPLY HARDWARE

2.1 DRILL HOLES

MARK DOOR FACE AND DRILL HOLES IN ACCORDANCE WITH THE DIAMETERS SUGGESTED. SEE ATTACHED TEMPLATE

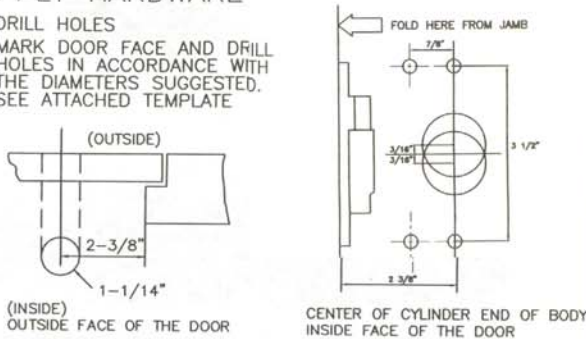

3. APPLY RAIL ASSEMBLY

1. CHECK THE SIZE OF DEVICE, IF CUTTING TO LENGTH IS REQUIRED.
2. DETERMINE CUT OFF LENGTH "X" BY SUBTRACTING 1 3/4" FROM "Y". MARK CUT OFF POINT ON MOUNTING RAIL.
3. DEPRESS ARM INTO RAIL OPENING AND SLIDE RAIL ONTO CHASIS. LEVEL RAIL AND FASTEN CHASIS AND MOUNTING PLATE.

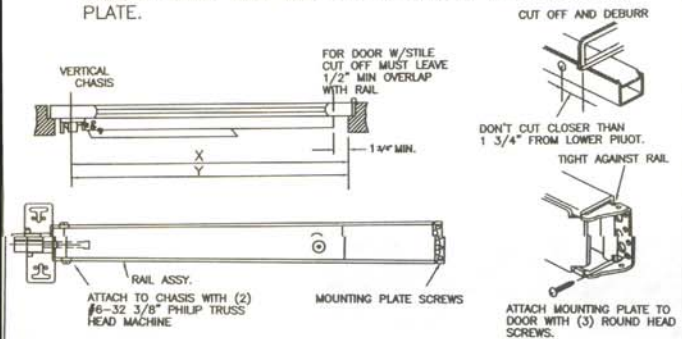

2.2 INSTALL CYLINDER

1. INSERT THE CYLINDER THROUGH CYL RING THE HOLE ON THE DOOR.
2. KEEP THE TAIL PIECE HORIZONTAL.
3. MOUNT LINER ON INSIDE OF DOOR AND
4. TAILPIECE PROJECTION OVER INSIDE OF DOOR IS SUGGESTED IN THE RANGE 9/32"~15/32". IF NECESSARY, USEA PLIER TO BEND AND CUT TO DESIRED LENGTH.



4. APPLY COVER AND STRIKES

