

INSTALLATION INSTRUCTION FOR PANIC VERTICAL ROD EXIT DEVICE.

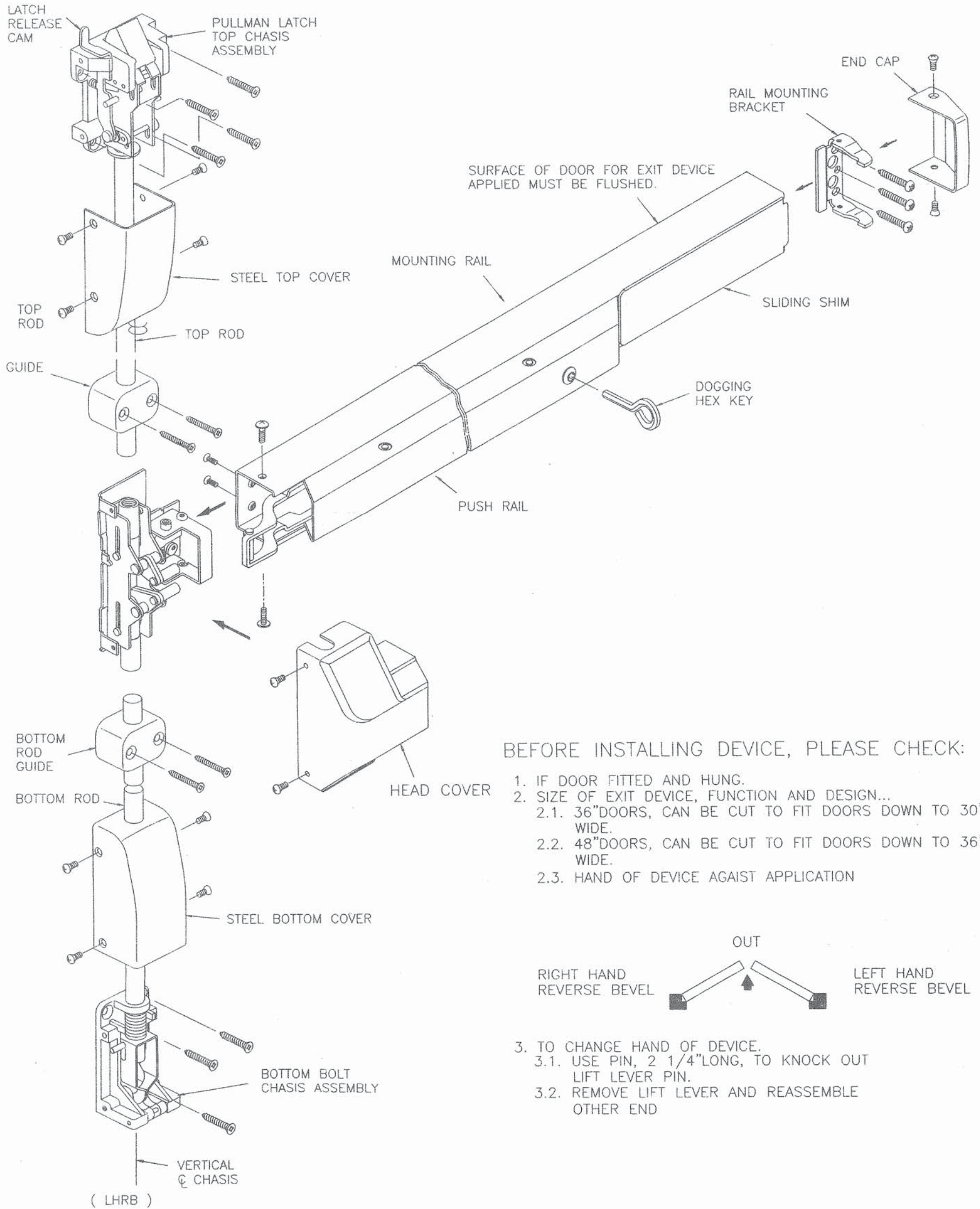

BEFORE INSTALLING DEVICE, PLEASE CHECK:

1. IF DOOR FITTED AND HUNG.
2. SIZE OF EXIT DEVICE, FUNCTION AND DESIGN...
 - 2.1. 36" DOORS, CAN BE CUT TO FIT DOORS DOWN TO 30" WIDE.
 - 2.2. 48" DOORS, CAN BE CUT TO FIT DOORS DOWN TO 36" WIDE.
 - 2.3. HAND OF DEVICE AGAINST APPLICATION

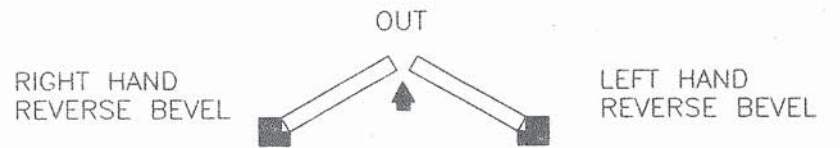

3. TO CHANGE HAND OF DEVICE.
 - 3.1. USE PIN, 2 1/4" LONG, TO KNOCK OUT LIFT LEVER PIN.
 - 3.2. REMOVE LIFT LEVER AND REASSEMBLE OTHER END

1. MARK VERTICAL AND HORIZONTAL REFERENCE LINE ON DOOR.

DETERMINE BACKSET TO LOCATE VERTICAL REFERENCE LINE.
 1. IF LOCK STILE IS 4 1/2" WIDE OR WIDER, BACKSET IS 2 3/4".
 2. IF LOCK STILE IS LESS THAN 4 1/2" WIDE, BACKSET IS HALF OF THE EXPOSED WIDTH OF LOCK STILE.

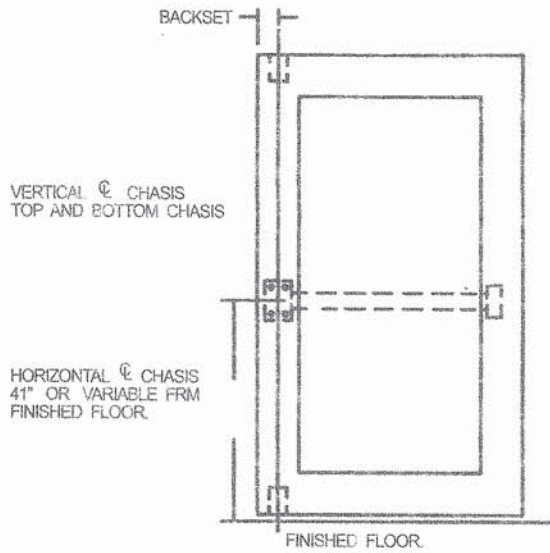

2. PREPARE DOOR

TAPE TEMPLATE ON INSIDE OF DOOR ALONG REFERENCE LINE. SPOT AND DRILL HOLE.

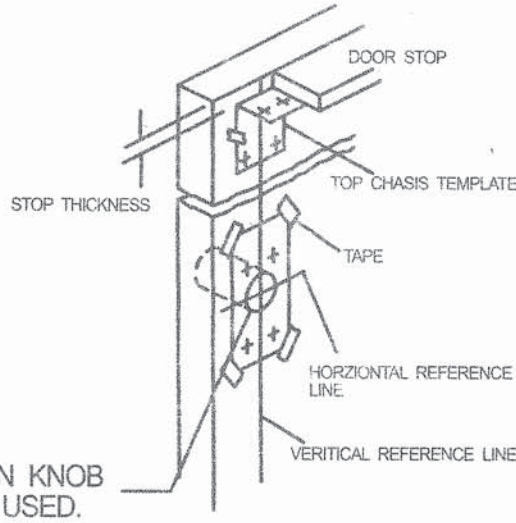

3. APPLY TRIM+CHASIS

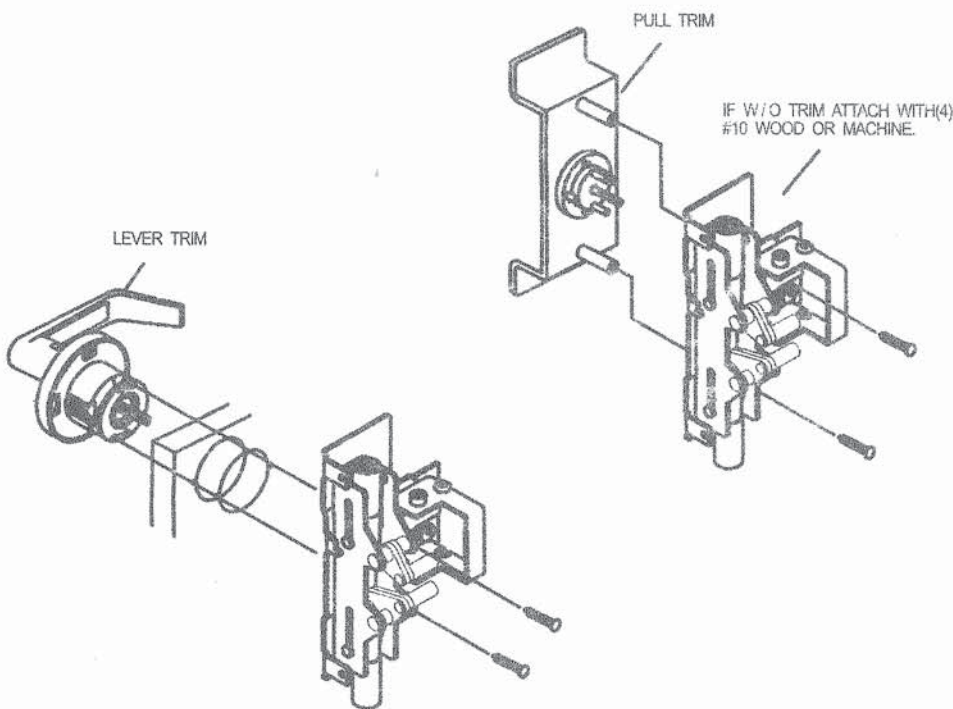

4. ATTACH TOP AND BOTTOM CHASIS

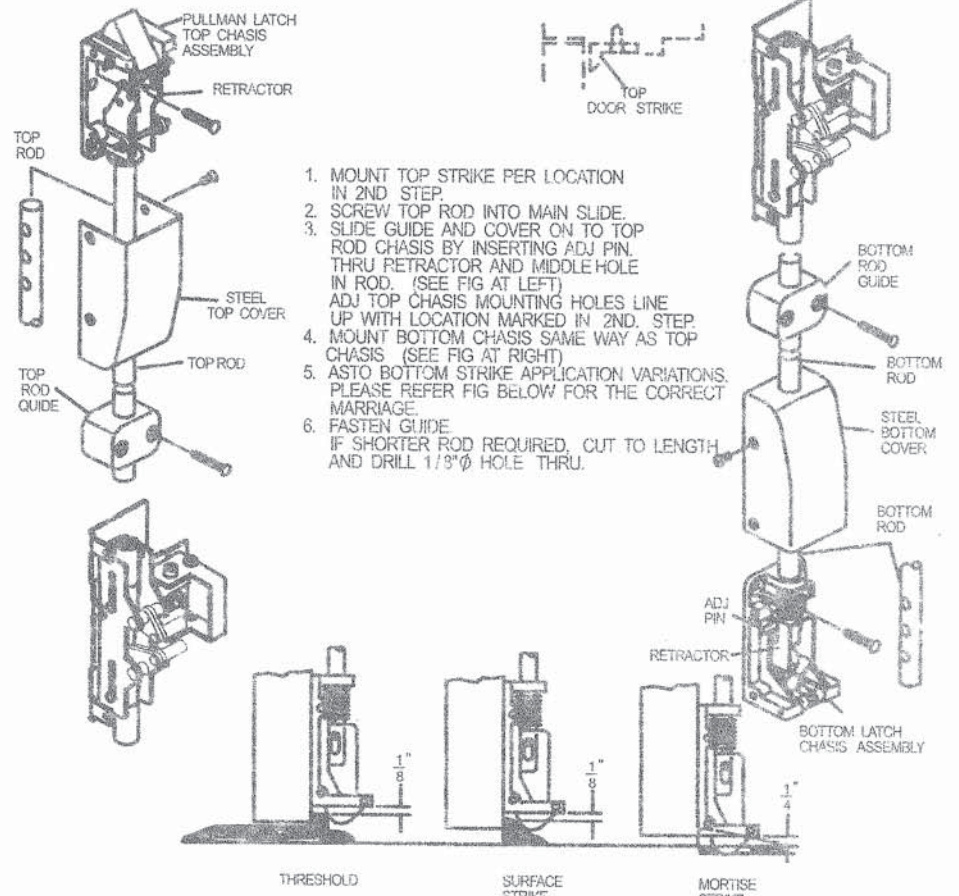

5. APPLY RAIL ASSEMBLY

1. CHECK THE SIZE OF DEVICE, IF CUTTING TO LENGTH IS REQUIRED.
 2. DETERMINE CUT OFF LENGTH "X" BY SUBTRACTING 1 3/4" FROM "Y". MARK CUT OFF POINT ON MOUNTING RAIL.

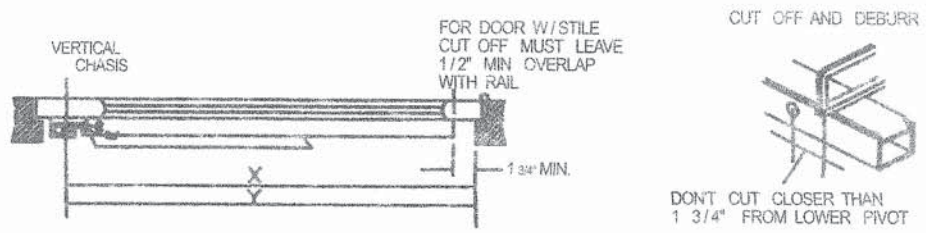

3. DREPRESS ARM INTO RAIL OPENING AND SLIDE RAIL ONTO CHASIS. LEVEL RAIL AND FASSTEN CHASIS AND MOUNTING PLATE.

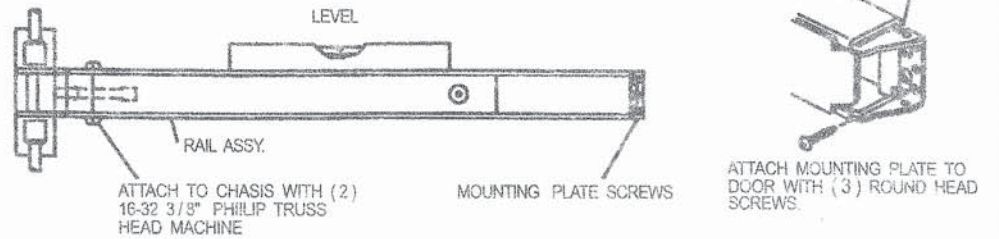

6. APPLY COVER

CHECK FINAL OPERATION OF DEVICE AND ADJUST THEN FASTEN COVERS.

