

PARALLEL ARM INSTALLATION CLOSER MOUNTED ON DOOR ON PUSH SIDE

This drawing shown is RIGHT HAND DOOR, For LEFT HAND DOOR should be install in symmetry

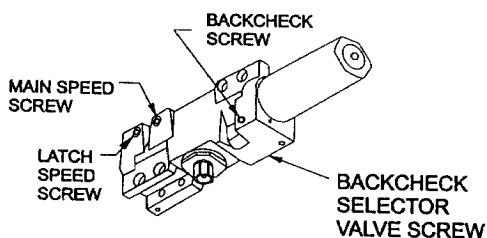
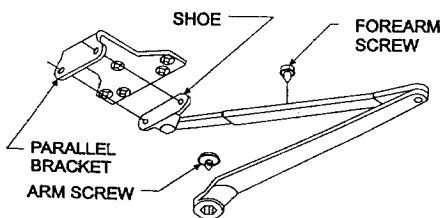
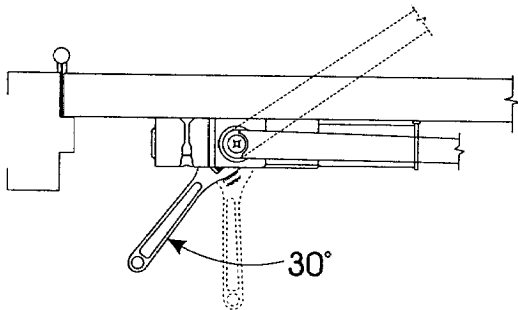
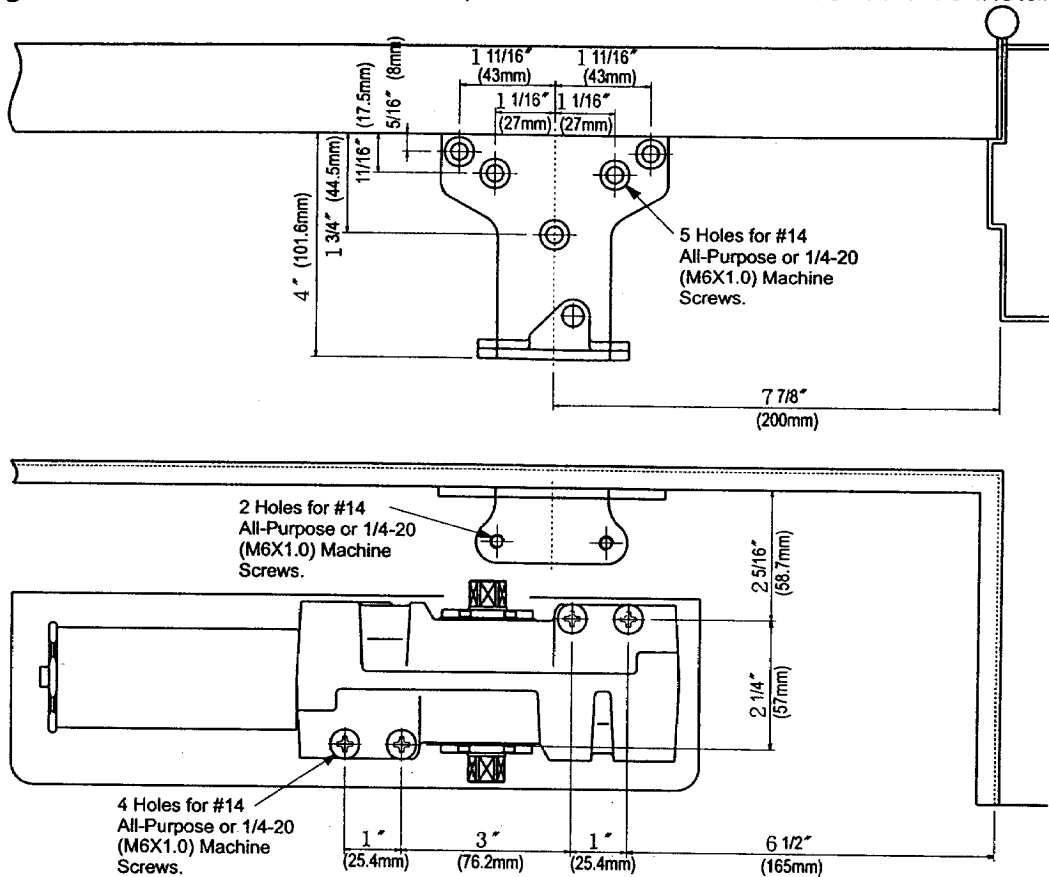

1. Before installation, turn Back Check selector valve (found on the opposite side of closer from back check screw side) ALL THE WAY IN (CLOCKWISE).
2. Adjust spring power to match door width as indicated by chart on page 1.
3. Mount closer on door as dimensions shown. Tube end toward latch. If pivots are used, locate closer and parallel bracket from CENTERLINE OF PIVOT.
4. Place open end wrench on bottom shaft and turn toward hinge jamb about 30° , and then place main arm on top shaft, insert arm screw into top of shaft and tighten.
5. Attach parallel bracket on frame as dimensions shown.
6. Attach rod and shoe to parallel bracket as shown.
7. Insert rod in forearm, and then insert main arm to closer parallel to door. Then insert forearm set screw and tighten.
(IF HOLD OPEN ARM IS USED, THE NUT IS ON THE TOP FOR RH DOOR AND BOTTOM FOR LH DOOR)

REGULATION:

A 'Normal' closing time from 90° open position to door stop position is 4-6 secs, evenly divided between main swing speed and latch swing speed. Use socket key (furnished) to adjust speed. To slow main speed of door, turn regulating screw nearest shaft clockwise. To slow latch speed, turn regulating screw nearest hinge clockwise.

BACK CHECK

To increase back-check force, turn regulating screw nearest latch clockwise. DO NOT USE ABRUPT BACKCHECK OR EXPECT DOOR CLOSER TO ACT AS A DOOR STOP.

COVER

Place insert in proper cutout, then push cover against door. Tighten both cover screw securely.

HOLD OPEN ADJUSTMENT (when hold open arm is used)

Loose adjusting nut, open door to desired hold open position and tighten nut. Do not permit door to swing beyond hold open setting.