

INSTALLATION INSTRUCTION FOR 7760V SERIES PANIC VERTICAL ROD EXIT DEVICE.

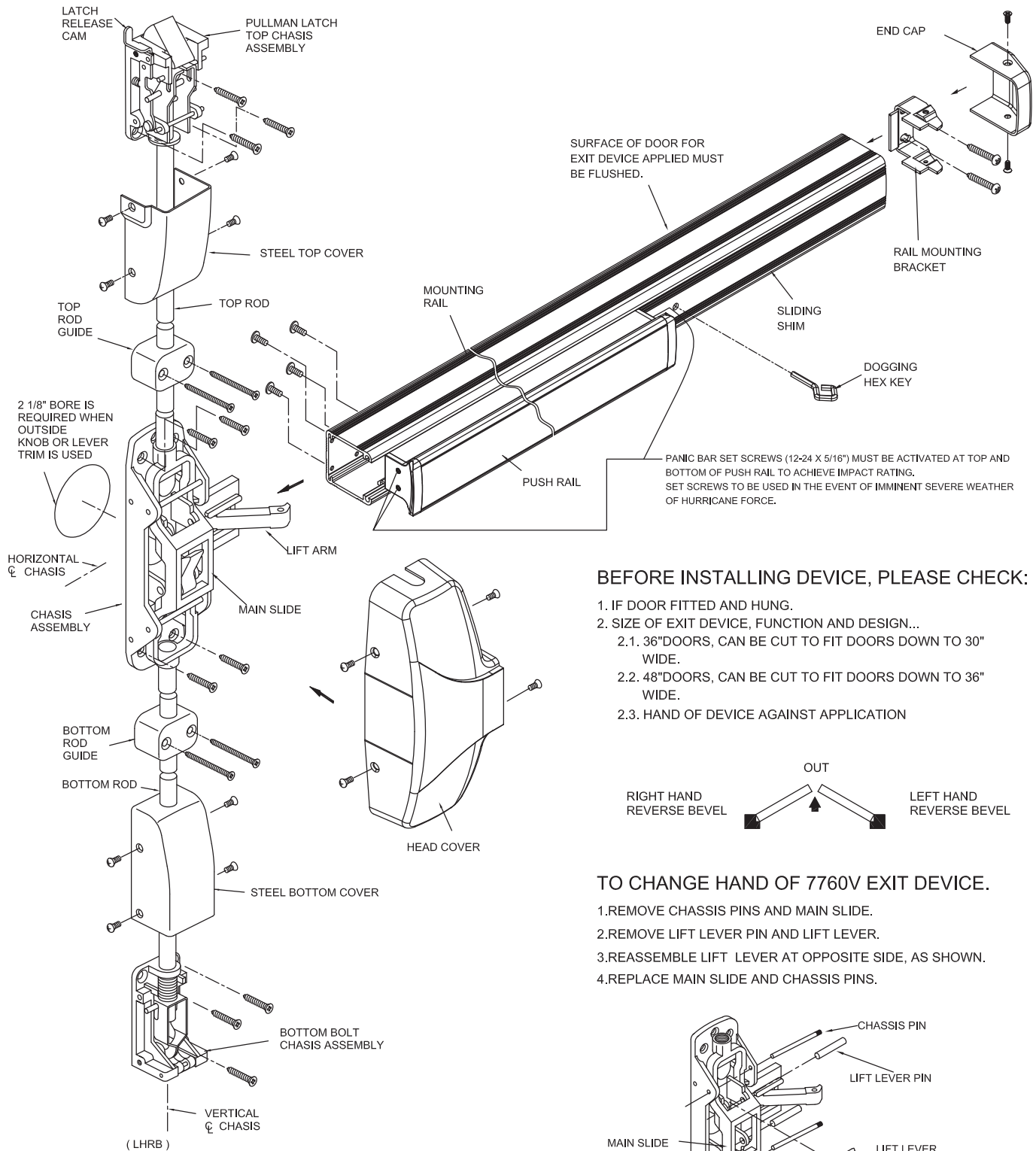

1. MARK VERTICAL AND HORIZONTAL REFERENCE LINE ON DOOR.

DETERMINE BACKSET TO LOCATE VERTICAL REFERENCE LINE.

1. IF LOCK STILE IS 4-1/2" WIDE OR WIDER, BACKSET IS 2-3/4".
2. IF LOCK STILE IS LESS THAN 4-1/2" WIDE, BACKSET IS HALF OF THE EXPOSED WIDTH OF LOCK STILE.

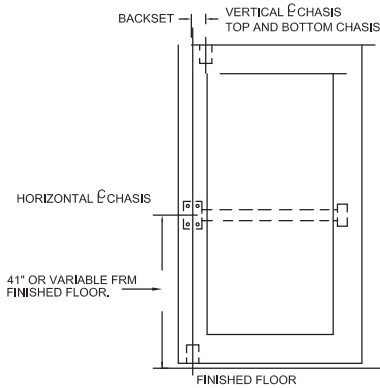

2. PREPARE DOOR

TAPE TEMPLATE ON INSIDE OF DOOR ALONG REFERENCE LINE SPOT AND DRILL HOLE.

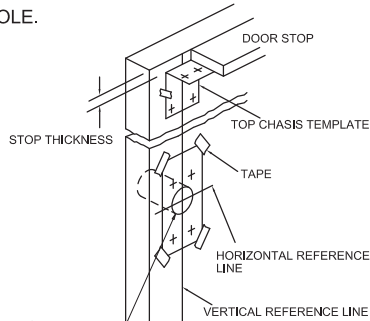

2-1/8" BORE WHEN KNOB AND LEVER TRIM IS USED.

3. APPLY HARDWARE

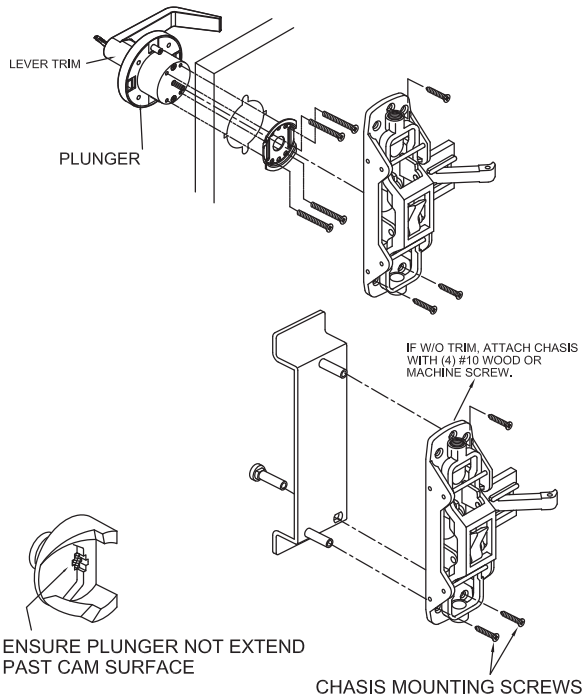

4. ATTACH TOP AND BOTTOM CHASIS

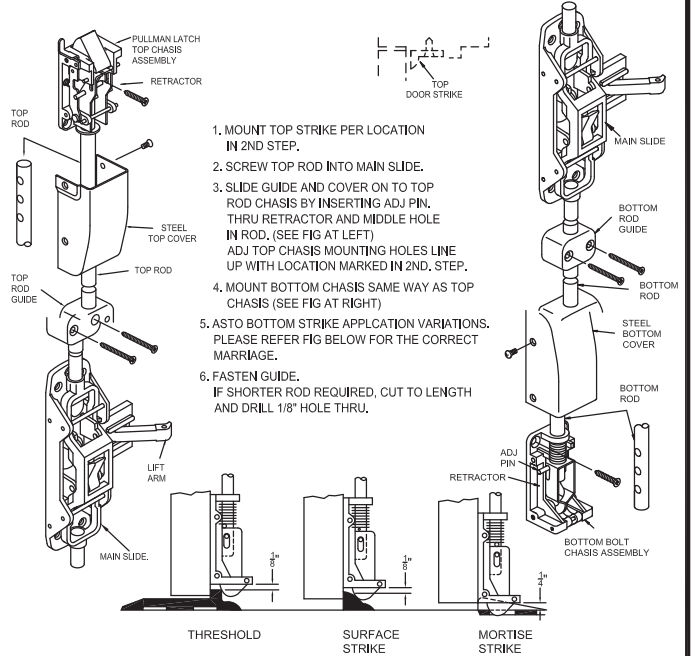

5. APPLY RAIL ASSEMBLY

1. CHECK THE SIZE OF DEVICE, IF CUTTING TO LENGTH IS REQUIRED.
2. DETERMINE CUT OFF LENGTH "X" BY SUBTRACTING 1-3/4" FROM "Y", MARK CUT OFF POINT ON MOUNTING RAIL.

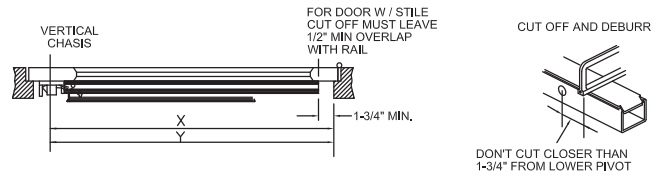

3. DEPRESS ARM INTO RAIL OPENING AND SLIDE RAIL ONTO CHASIS. LEVEL RAIL AND FASTEN CHASIS AND MOUNTING PLATE.

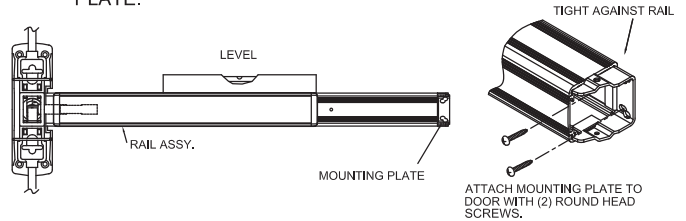

6. APPLY COVER

CHECK FINAL OPERATION OF DEVICE AND ADJUST, THEN FASTEN COVERS.

