

CAL-ROYAL PRODUCTS, INC. Cylinder Dogging Kits

Assembly and Installation Instructions

For 2200/2260V and 9800/9860V Series Panic Rim & Vertical Rod

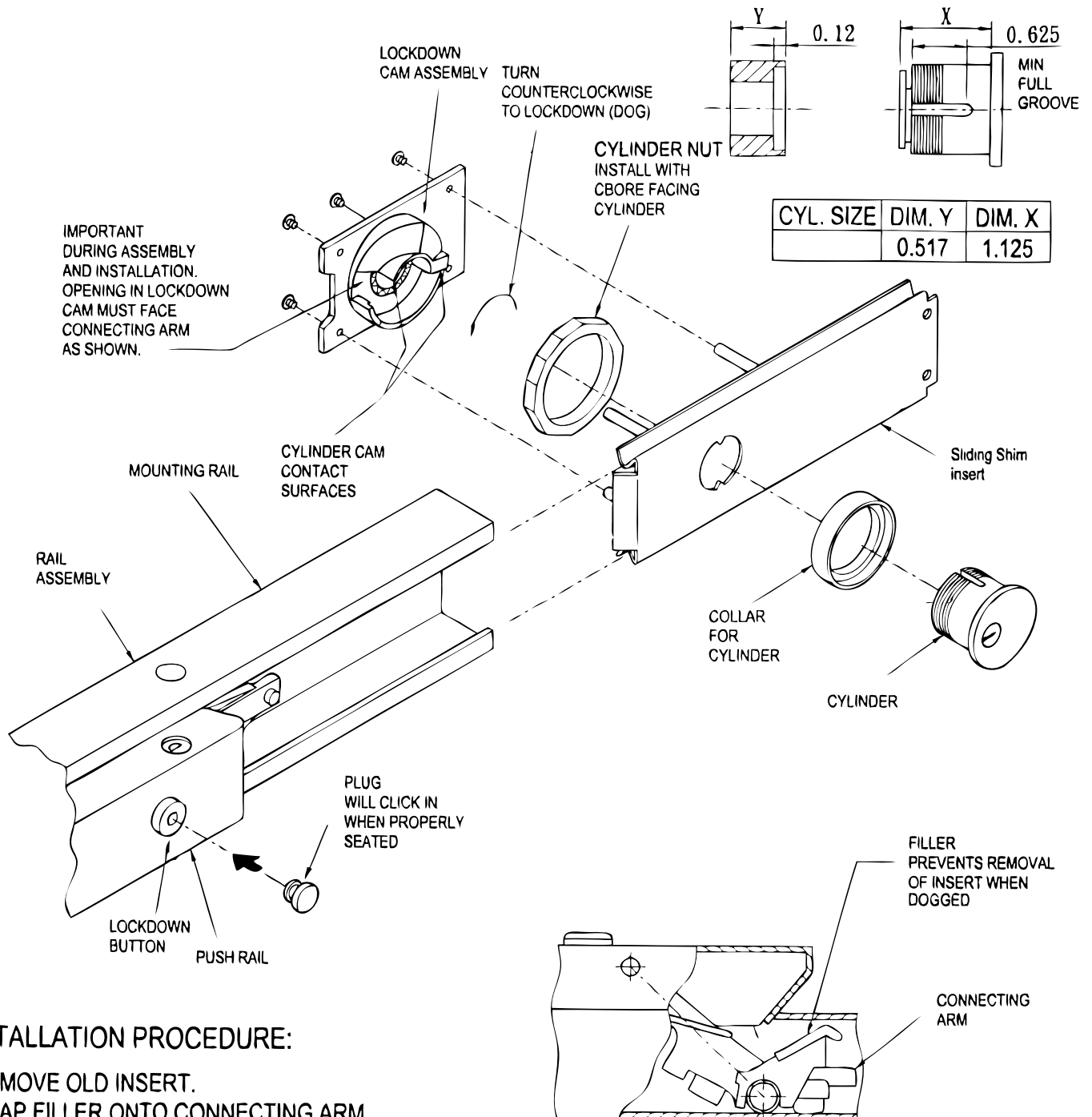

INSTALLATION PROCEDURE:

1. REMOVE OLD INSERT.
2. SNAP FILLER ONTO CONNECTING ARM.
3. ASSEMBLE CYLINDER AND COLLAR TO INSERT WITH CYLINDER NUT.
4. ASSEMBLE LOCKDOWN CAM ASSEMBLY TO INSERT WITH 4 SCREWS.
5. SLIDE INSERT INTO RAIL ASSEMBLY.
6. MAKE OPERATIONAL CHECK OF DOGGING (TURN COUNTERCLOCKWISE TO DOG).
7. PRESS PLUG INTO ALLEN WRENCH LOCKDOWN BUTTON.

NOTES: WHEN INSERT IS USED (1) SLIDE INSERT INTO RAIL, (2) DOG PUSH RAIL, (3) CUT OFF EXCESS FLUSH WITH MOUNTING RAIL.

