

INSTALLATION INSTRUCTIONS FOR TRIM OF PANIC EXIT DEVICE

WHEN YOUR DOOR HAS CYLINDRICAL LOCK CUT-OUT

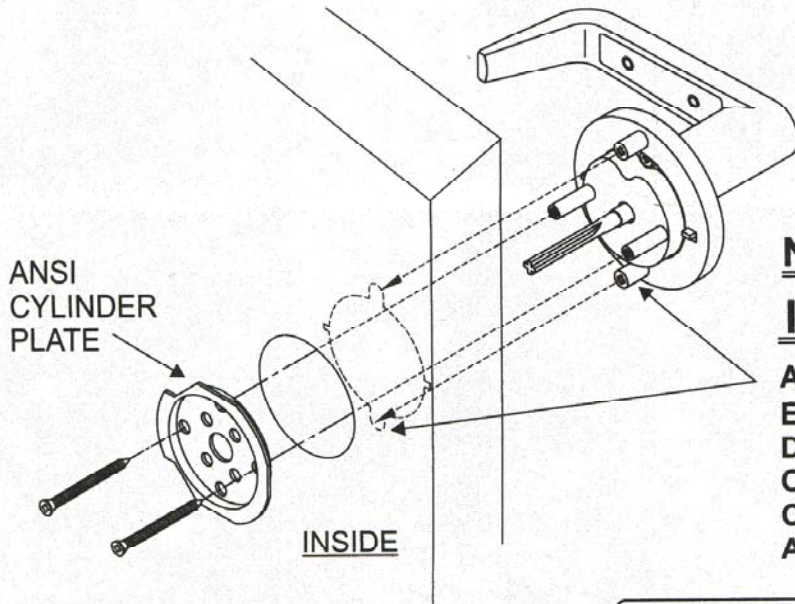

NOTE:

IMPORTANT!

ALIGNMENT STUDS **MUST** ENTER INTO (2) 5/16" FIELD DRILLED HOLES ON OUTSIDE OF DOOR (EXISTING SLOTS CAN BE ELONGATED WITH A FILE).

**MANUFACTURER'S WARANTEE INVALID
IF SECURITY STUDS ARE REMOVED.**

TEMPLATE

