

INSTRUCTIONS FOR INSTALLING CAL- ROYAL MR9800 SERIES MORTISE EXIT DEVICE

Available stock length

- For 32" doors, Device can be cut to fit doors down to 24" wide
- For 36" doors, Device can be cut to fit doors down to 32" wide
- For 48" doors, Device can be cut to fit doors down to 26" wide

THIS EXIT DEVICE IS HANDED
CHECK HAND OF DEVICE AGAINST APPLICATION

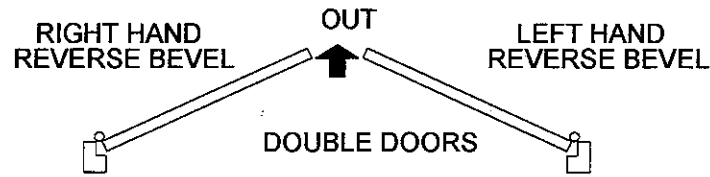

Door Surface must be flush to allow Exit Device rest on flat surface of the door

End Cap

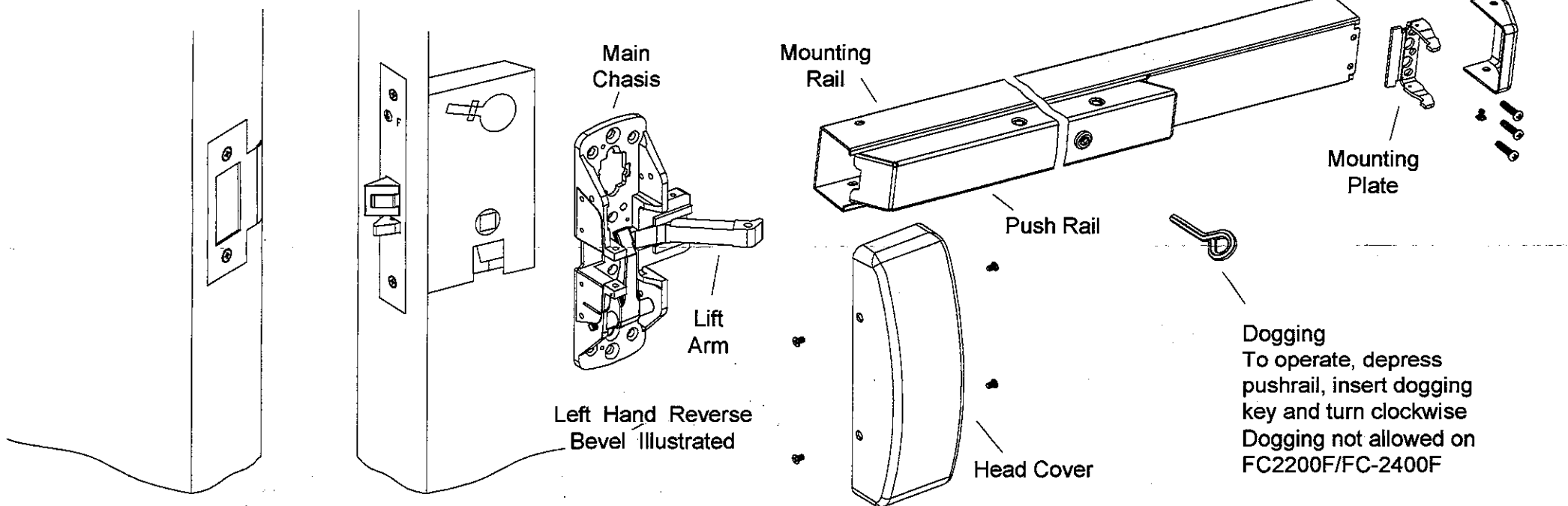

1. PREPARE DOOR AND MOUNT LOCK

Tape templates to inside face and edge of door according to directions given on template. Drill holes and mortise dood for lock as indicated.

Fasten mortise lock in place

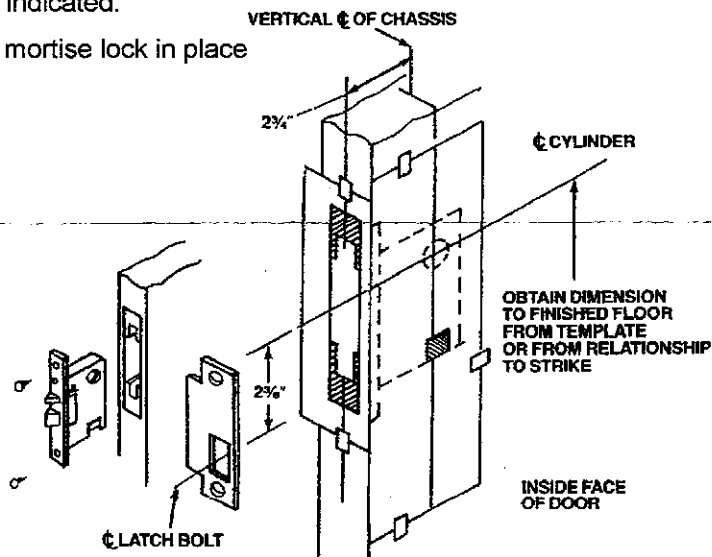

2. ATTACH CHASSIS TO DOOR

- 2.1. Attach chassis to Rail, then lock push rail down, using dogging key
- 2.2. Position chassis and rail on door, so that Lever arm is under rear section of Mortise lock lever. Then lift up until latchbolt is completely retracted
- 2.3. With chassis in this position and rail horizontal, mark location of chassis mounting holes. Drill holes for screws
- 2.4. Release Push rail, and dis-ass'y chassis from rail. Then, mount chassis on door

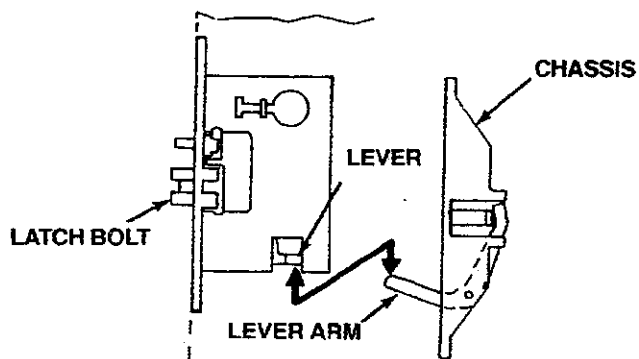
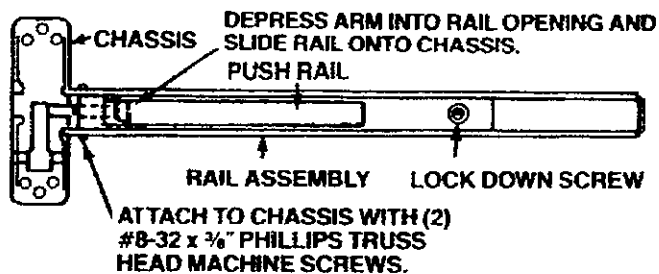

3. APPLY EXTERIOR TRIMS

- 3.1. If Esc Lever trim is used, attach outside trim and cyl
- 3.2. If Thumbpiece trim is used, attach outside trim and cyl.

And tighten cyl set screw in lock front

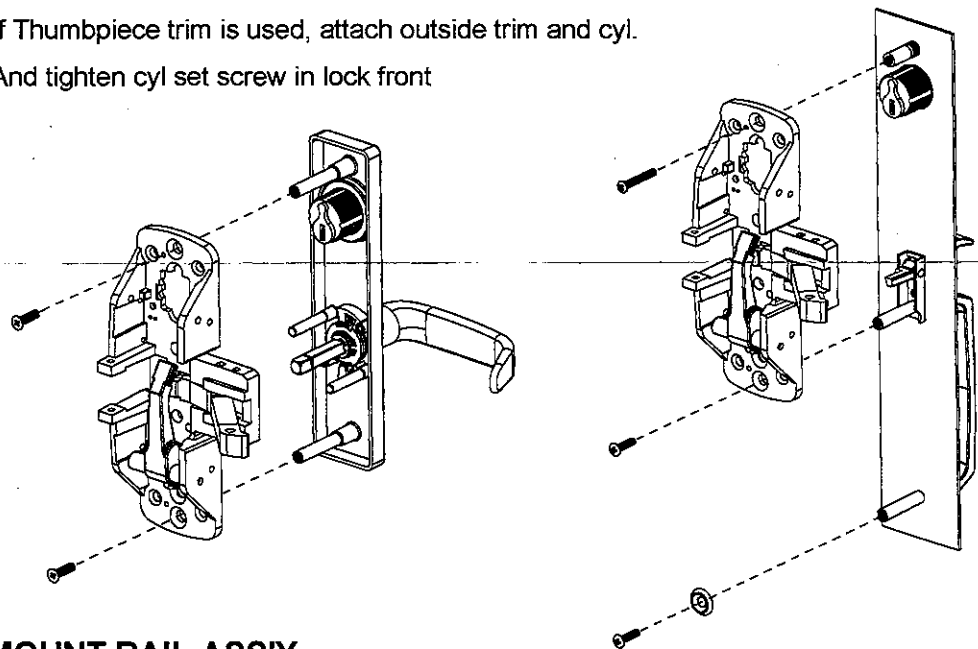

4. MOUNT RAIL ASS'Y

- 4.1. Determine cut-off dimension "X" by subtracting 1-1/8" from dimension "Y"

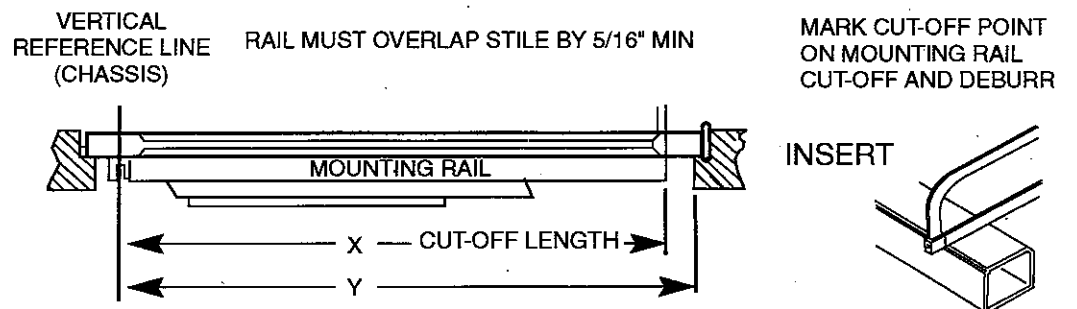

5. ATTACH COVER

- Attach cover to chassis with four cover screws

