

CAL- ROYAL Cyl Dogging Kits

Ass'y and Installion Instructions

For #2200/2260V #9800/9860V series Panic Rim & Vert Rod Device

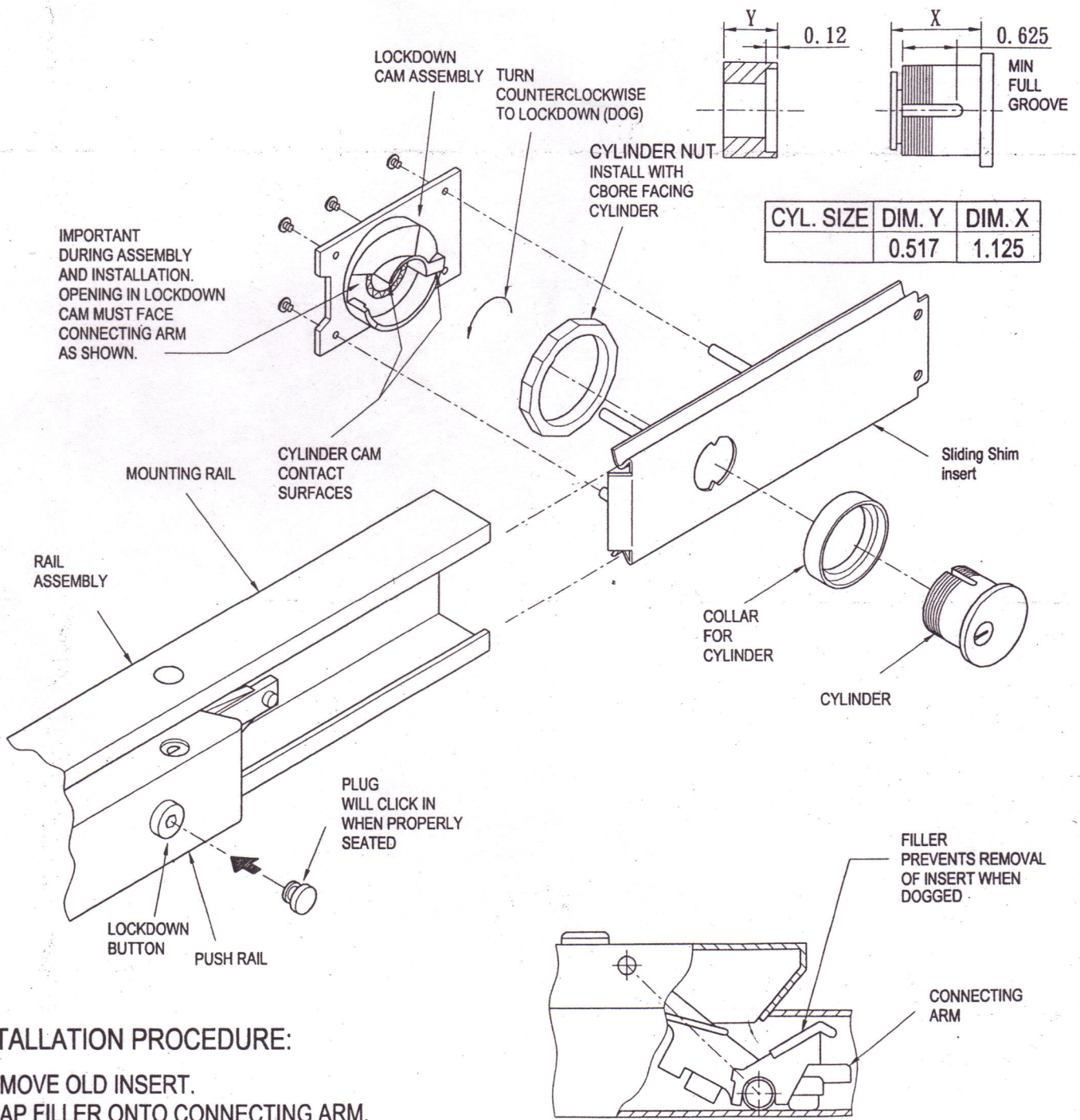

INSTALLATION PROCEDURE:

- 1.REMOVE OLD INSERT.
- 2.SNAP FILLER ONTO CONNECTING ARM.
- 3.ASSEMBLE CYLINDER AND COLLAR TO INSERT WITH CYLINDER NUT.
- 4.ASSEMBLE LOCKDOWN CAM ASSEMBLY TO INSERT WITH 4 SCREWS.
- 5.SLIDE INSERT INTO RAIL ASSEMBLY.
- 6.MAKE OPERATIONAL CHECK OF DOGGING (TURN COUNTERCLOCKWISE TO DOG).
- 7.PRESS PLUG INTO ALLEN WRENCH LOCKDOWN BUTTON.

NOTES: WHEN INSERT IS USED (1) SLIDE INSERT INTO RAIL, (2) DOG PUSH RAIL,