

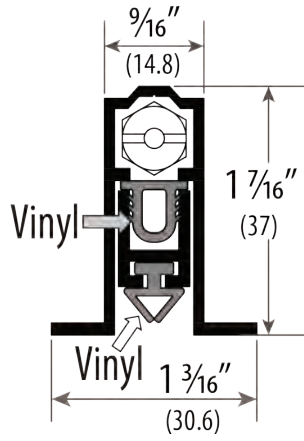

ADB-703

Automatic Door Bottom



ITEM/FINISH:
ADB-703

LENGTH: 36" & 48"
VINYL INSERT
MILL FINISH ALUMINUM &
DURO

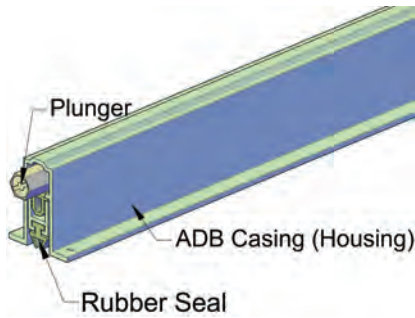

TESTING / RATINGS:



GASKETING MATERIAL FOR FIRE DOORS INTENDED FOR APPLICATION TO UL LISTED STEEL FRAMES AND/OR CLASSIFIED STEEL COVERED COMPOSITE TYPE, AND HOLLOW METAL TYPE FIRE DOORS RATED UP TO 3HRS. WOOD AND PLASTIC COVERED COMPOSITE TYPE FIRE DOORS RATED UP TO 1-1/2 HRS. AND WOOD CORE TYPE FIRE DOORS RATED UP TO 20 MINUTES. 432Y

AUTOMATIC DOOR BOTTOMS (ADB)

Installation Guidelines:

1. Detach door from hinge and cut mortise on the bottom of the door according to the dimensions of the unit.
Reminder: If the door is fire labeled, mortise preparation must be done by the door manufacturer to ensure compliance with door standards.
2. Measure the door from both ends to get the exact required length for the door bottom less 1/16" both end of the ADB. Use power cutting tools like table saw or chop saw to have an excellent level cut. Important Reminder: You must trim on the opposite side of the actuating plunger. The allowable size that can be trimmed is 1-1/2" away from the screw towards the edge of the ADB unit. See illustration #1.
3. After the door has been prepped, install the door bottom with the plunger towards the hinge jamb side. Fasten unit with screws provided. Ideal clearance between the unit and the finished floor is 3/8".
4. Set the ADB by turning the actuating plunger clockwise or counter clockwise until the rubber seal gasket touches the floor surface (AFF or Threshold).
5. Lastly, install the end plate on both ends of the ADB.

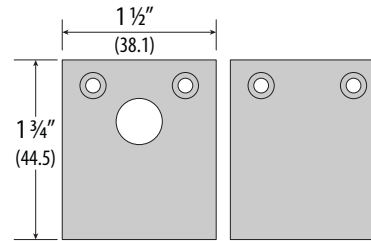

Packaging includes:

- (1) Automatic Door Bottom
- End Plate
- Screw pack (Size #6 x 3/4")

Tools Required

- Measuring tape
- Marker
- Power tools
- Screw driver
- Cutting tools

Mortised: the plunger contacts the rabbet. See illustration #2.

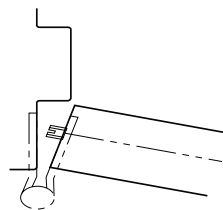
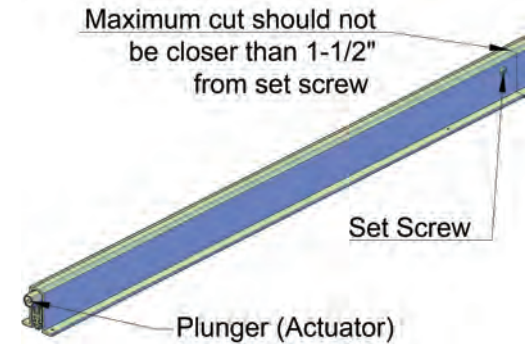
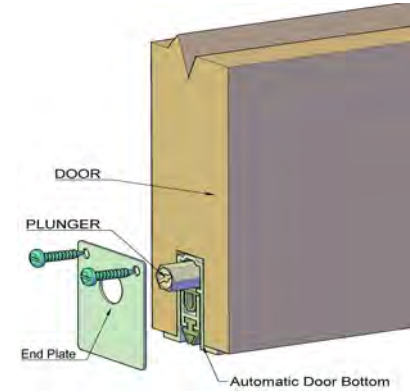

ILLUSTRATION 2

CONCEALED (MORTISED)



36" length = 8" cut maximum
48" length = 14" cut maximum

ILLUSTRATION 1 (Trimming Guideline)

