

CR3000

DIGITAL KEYPAD DOOR LOCK
HEAVY DUTY GRADE 1

Available with Interchangeable Core

FEATURES

- MASTER CODE
- 10 MANAGER CODES
- 1 SUB-MASTER CODE
- 90 USER CODES
- 5 SERVICE CODES
- PASSAGE MODE
- WEATHER RESISTANT
- BUZZER & LED INDICATORS
- ANTI-TAMPER LOCKOUT
- LONG-LIFE BATTERY OPERATION
- 2 REMOTE SWITCHES
- INTERCHANGEABLE CORE
- CLUTCH TECHNOLOGY
- NON-HANDED, REVERSIBLE
- ENABLE & DISABLE USERS MODE
- TACTILE METAL KEYPAD
- USER FRIENDLY
- EASY INSTALLATION & PROGRAMMING
- 2 YEAR WARRANTY



MEETS
The Buy American Act



Meets ADA requirements
Specially designed for Barrier Free Application
Conforms with ANSI A156.2 Series 4000, Grade 1
Exceeds 1,000,000 cycles



INTERIOR

SPECIFICATIONS

APPLICATIONS

For offices, schools, hospitals, apartments, hotel / motel, residential, commercial and public buildings.

DOOR RANGES

1 3/8" to 2" thickness.

BACKSET

2 3/4" Standard, 2 3/8", 3 3/4", 5" and 2 3/4" anti-friction latch with 3/4" throw for pair of fire doors optional.

LATCH FACEPLATE

Standard 2 1/4" x 1 1/8" for 2 3/4" backset.
Optional 2 1/4" x 1 1/8" for 2 3/8" backset.

STRIKES

ASA strike standard, "T" and full lip strike available on request.

ANSI STANDARDS

Meets or exceeds BHMA / ANSI A 156.2 Series 4000 Grade 1 requirements.

POWER SUPPLY

4 AA Batteries (comes standard in packing)

CLUTCH

Clutch technology allows turning of lever without retracting latch, thus prolonging the life of the lock by reducing stress on the spindle and other parts.

CYLINDER & KEYWAYS

6 pin solid brass "C" keyway standard. Schlage E, Schlage C-K, Russwin D1-2-3-4, Corbin 59/60, Corbin-Russwin L4, Sargent LA-LB-LC, Falcon / Weiser E, Arrow A, Yale 8, Yale GA and Kwikset. Can also accept Medeco, Assa, Kaba and Cal-Royal (HSK) High Security Cylinders.

INTERCHANGEABLE CORE (IC)

Interchangeable Core locks will accept compatible 6 or 7 pin cores with BEST, FALCON and ARROW. Prefix "IC" before part number.

WEATHER RESISTANT

All models are weather resistant for temperature ranges of +158°F to -22°F (+70°C to -30°C).

KEYPAD

12 programmable buttons for multi-level access functions including group or individual user codes, master and management codes, passage and emergency or service codes.

FINISHES AVAILABLE		
BHMA SYMBOL	US CODE	DESCRIPTION
626	US26D	Satin Chrome
613	US10B	Oil Rubbed Bronze



Refer to price list for stock finishes and functions

FUNCTIONS

CR3000

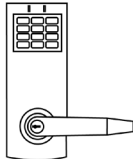

Latch bolt operated by lever from either side, except outside has to enter a pre-programmed code in the keypad in order to retract the latch upon turning the lever. Key overrides the use of the keypad.

ICCR3000

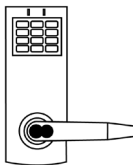

Latch bolt operated by lever from either side, except outside has to enter a pre-programmed code in the keypad in order to retract the latch upon turning the lever. Key overrides the use of the keypad. Available with Interchangeable Core.

CR3030

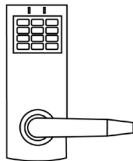

Latch bolt operated by lever from either side, except outside has to enter a pre-programmed code in the keypad in order to retract the latch upon turning the lever.

DOOR PREPARATION

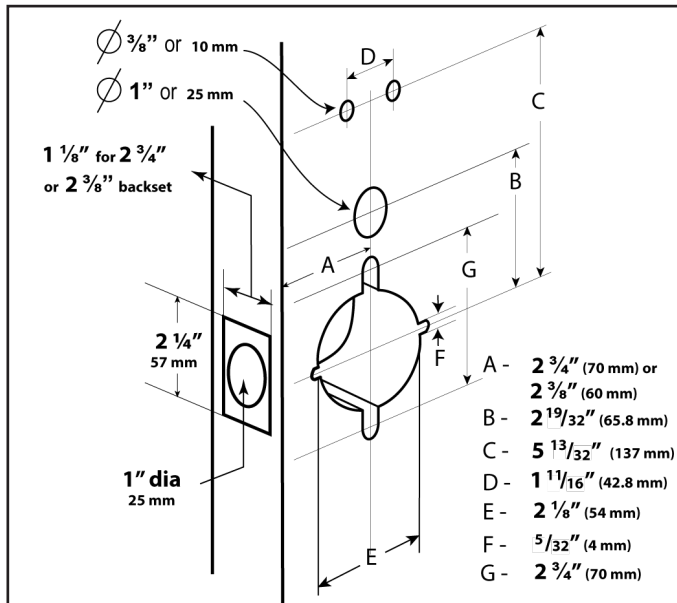

FEATURES

- **Master Code** – performs all programming functions.
- **Sub-Master Code** – performs all programming functions except delete or change Master Code.
- **Manager Codes** – CR3000 can accommodate 10 Managers each having different codes and under each Manager has 9 Users (1 Manager + 9 Users = 1 Bank). Managers are capable of programming / adding and deleting User codes under his Bank. Managers are also capable of accessing the next higher Bank until another Manager Code appears.
- **Service Codes (5)** – are one-time codes only. It cannot be used again. Once a Service Code is entered, the unit will unlock but will automatically delete the code.
- **Passage Mode** – once enabled, the unit is unlocked continuously until "Disable Passage Mode" is initiated.
- **Tones and LED Indicators** – can be programmed for different settings. Making sure that every key pressed is confirmed by an accompanying LED and / or tone.
- **Next Free Code Location Finder** – no need of guessing what free location is available in entering a new code. CR3000 can pin point and tell you where the next available location is.
- **Code Locator Function** – CR3000 can tell you the exact location of a certain code. Making it easy to determine as to what manager a user code is under.
- **Keypad Anti-Tamper Lockout** – if an invalid code is entered 3 times in succession, the unit will turn off for 30 seconds to prevent tampering.
- **Remote Switch / Release** – CR3000 provides 2 Remote Switches. Either can be used for an emergency push button switch, or connected to alarm systems such as fire alarms.
- **Weather Resistant** – CR3000 are manufactured making sure that internal electronic parts are protected from moisture, dust, water and corrosion. All models are weather resistant for temperature ranges of +158°F to -22°F (+70°C to -30°C).
- **Clutch Technology** – the outside lever of the CR3000 is a free-wheeling lever. If no valid code is entered, the lever will just turn freely without moving any parts inside, thus preventing breaking or tampering.
- **Non-Handed** – CR3000 can be installed for both left and right door opening.

Ⓜ(IC) Indicates function available with BEST, FALCON & ARROW Interchangeable Core.