

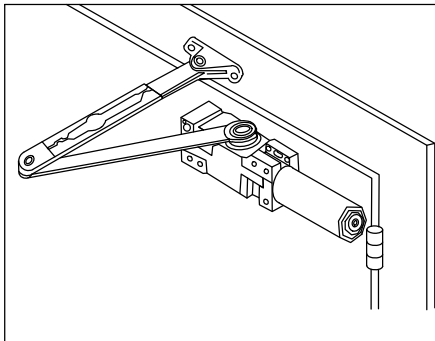

CR3049HO Hold Open Arm INSTALLATION INSTRUCTIONS

STANDARD MOUNT (PULL SIDE)

SEE PAGE 2



TOP JAMB MOUNT (PUSH SIDE)

SEE PAGE 3

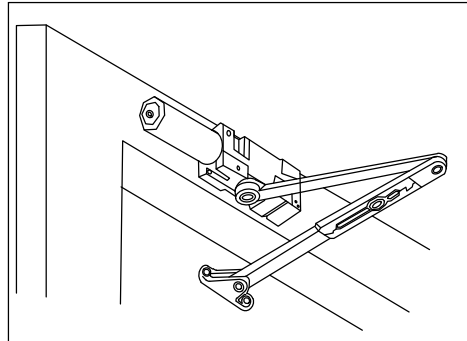

PARALLEL MOUNT (PUSH SIDE)

SEE PAGE 4

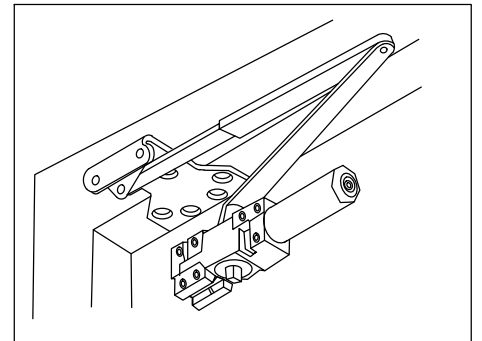

MAXIMUM DOOR WIDTH		FULL TURNS REQUIRED
EXTERIOR DOORS	EXTERIOR DOORS	
-----	5 lb-f*	5 TURNS C.C.W.
8.5 lb-f*	34"(864)	2 TURNS C.C.W.
30" (762)	38"(962)	0 TURNS
36"(914)	48"(1219)	5 TURNS C.W.
42"(1067)	54"(1372)	10 TURNS C.W.
48"(1219)	60"(1524)	15 TURNS C.W.

HOW TO DEFINE HAND OF DOOR

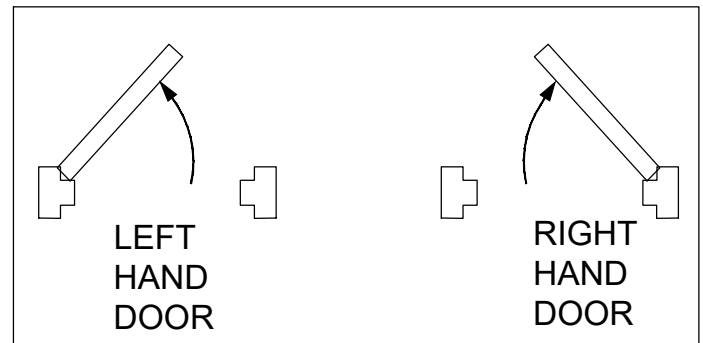

CONTROL RANGE

Back Check

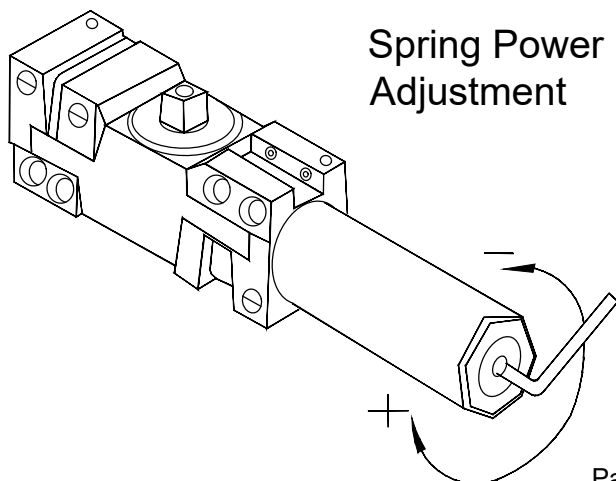
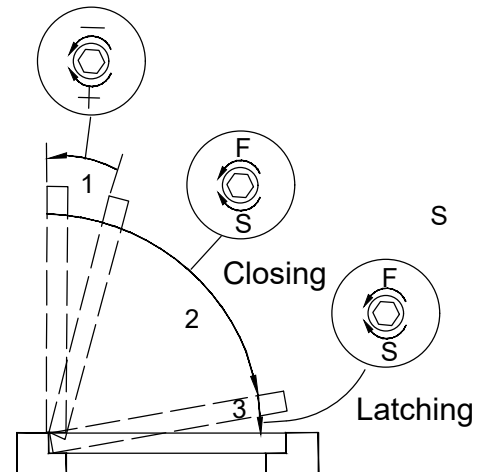

Spring Power Adjustment

STANDARD INSTALLATION CLOSER MOUNTED ON DOOR ON PULL SIDE



This drawing shown is LEFT HAND DOOR, For RIGHT HAND DOOR should be installed is symmetry.

2 Holes for #14
All-purpose or 1/4-20
(M6X1.0) Machine
Screws.

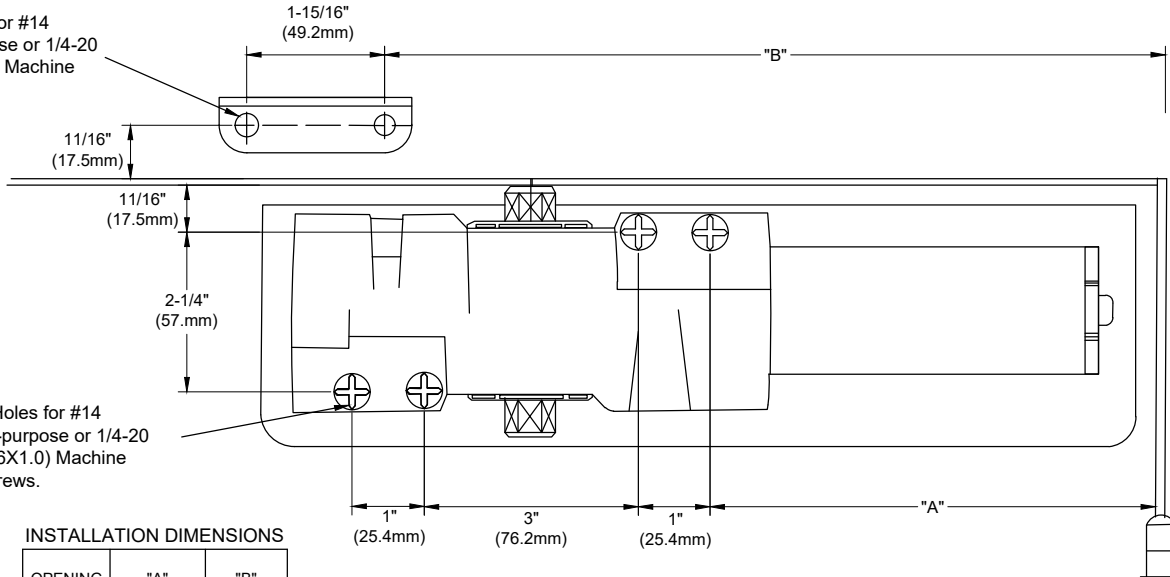

4 Holes for #14
All-purpose or 1/4-20
(M6X1.0) Machine
Screws.

INSTALLATION DIMENSIONS

OPENING	"A"	"B"
TO 100°	7-5/16" (185)	11-13/16" (300)
TO 130°	6-1/4" (159)	10-13/16" (275)

1. Adjust spring power to match door width as indicated by chart on page 1.
2. Mount closer on door as dimensions shown. Tube and toward hinge. If pivot are used, locate closer and shoe from CENTERLINE OF PIVOT.
(For offset pivots, please increase the marked dimensions by 1/8")
3. Place main arm on top of shaft, 100° to closer body. insert arm screw into top of shaft and tighten.
4. Attach shoe to frame as dimensions shown.(If more latching power required, rotate shoe 180°)
5. Open door and insert rod in forearm.
6. With forearm at right angle to door (90°), Insert forearm set screw and tighten.
(IF HOLD OPEN ARM IS USED, THE NUT IS ON THE TOP FOR RH DOOR AND BOTTOM FOR LH DOOR).

REGULATION:

A ' normal ' closing time from 90° open position to door stop position is 4-6 sec's, evenly divided between main swing speed and latch swing speed. Use socket key (furnished) to adjust speed. To slow main speed of door, turn regulating screw nearest shaft clockwise. To slow latch speed, turn regulating screw nearest latch clockwise.

BACK CHECK:

To increase back-check force, turn regulating screw nearest hinge clockwise.
DO NOT USE ABRUPT BACKCHECK OR EXPECT DOOR CLOSER TO ACT AS A DOOR STOP.

COVER

Place insert in proper cut-out, then push cover against door. Tighten both cover screw securely.

HOLD OPEN ADJUSTMENT (WHEN HOLD OPEN ARM IS USED)

Loose adjusting nut, open door to designed hold open position and tighten nut. Do not permit door to swing beyond open setting.

RIGHT HAND DOOR

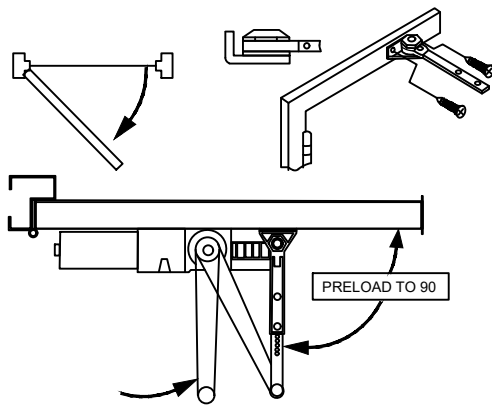

LEFT HAND DOOR

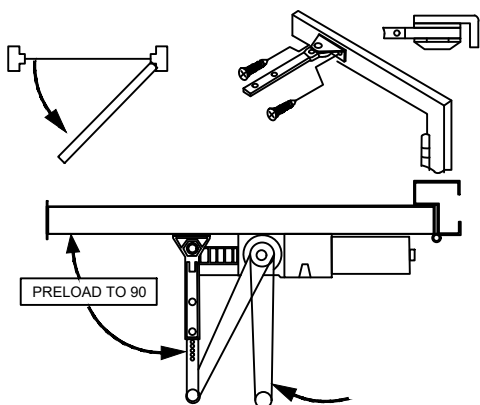

TOP JAMB INSTALLATION CLOSER MOUNTED TOP JAMB ON PUSH SIDE OF DOOR



This drawing shown is RIGHT HAND DOOR,
For LEFT HAND DOOR should be installed is symmetry.

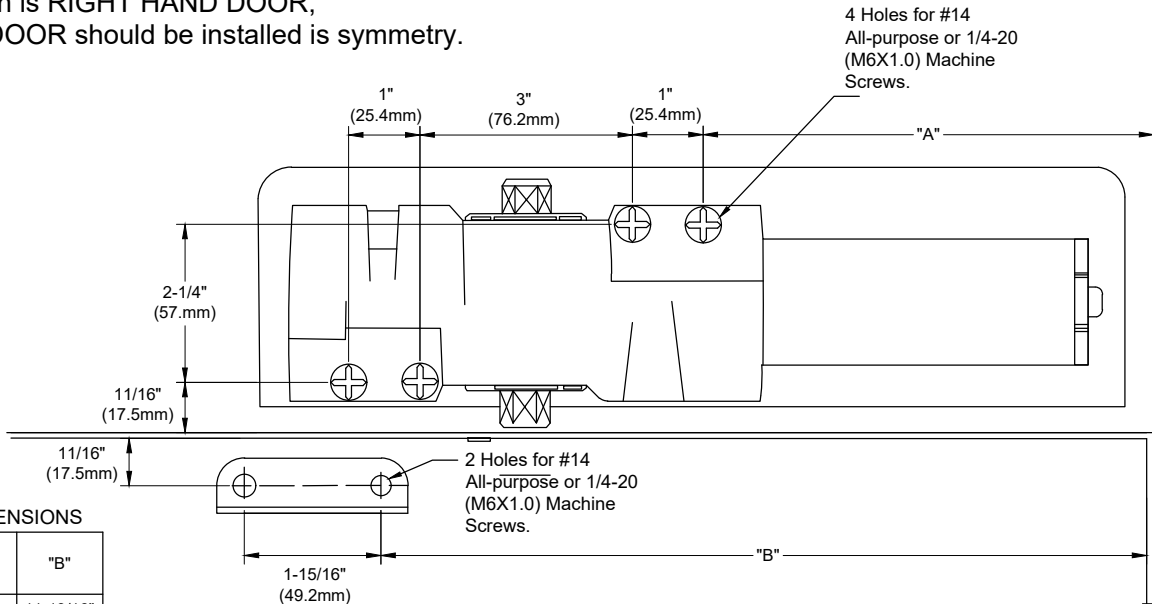

INSTALLATION DIMENSIONS

OPENNING	"A"	"B"
TO 100°	7-5/16" (185)	11-13/16" (300)
TO 130°	6-1/4" (159)	10-13/16" (275)

1. Adjust spring power to match door width as indicated by chart on page 1.
2. Mount closer on frame as dimensions shown. Tube and toward hinge. If pivot are used, locate closer and shoe from CENTERLINE OF PIVOT. (For offset pivots, please increase the marked dimensions by 1/8")
3. Place main arm on top of shaft, 100° to closer body. insert arm screw into top of shaft and tighten.
4. Attach shoe to door as shown. (If more latching power required, rotate shoe 180°)
5. Open door and insert rod in forearm. - for reveal 2-5/8" through 4-13/16" use long rod. For reveals 4-7/8" to 8" use FOREARM EXTENDED (ROD) - available from dealer.
6. With forearm at right angle to door (90°), insert forearm set screw and tighten. (IF HOLD OPEN ARM IS USED, THE NUT IS ON THE TOP FOR RH DOOR AND BOTTOM FOR LH DOOR).

REGULATION:

A normal closing time from 90° open position to door stop position is 4-6 sec's, evenly divided between main swing speed and latch swing speed. Use socket key (furnished) to adjust speed. To slow main speed of door, turn regulating screw nearest shaft clockwise. To slow latch speed, turn regulating screw nearest latch clockwise.

BACK CHECK:

To increase back-check force, turn regulating screw nearest hinge clockwise. DO NOT USE ABRUPT BACKCHECK OR EXPECT DOOR CLOSER TO ACT AS A DOOR STOP.

COVER

Place insert in proper cut-out, then push cover against door. Tighten both cover screw securely.

HOLD OPEN ADJUSTMENT (when hold open arm is used)

Loose adjusting nut, open door to desired hold open position and tighten nut. Do not permit door to swing beyond open setting.

RIGHT HAND DOOR

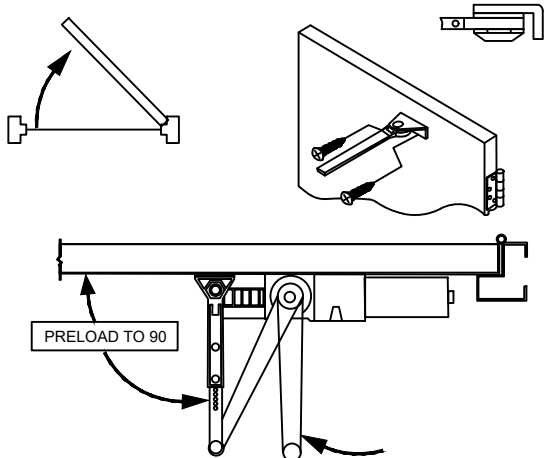

LEFT HAND DOOR

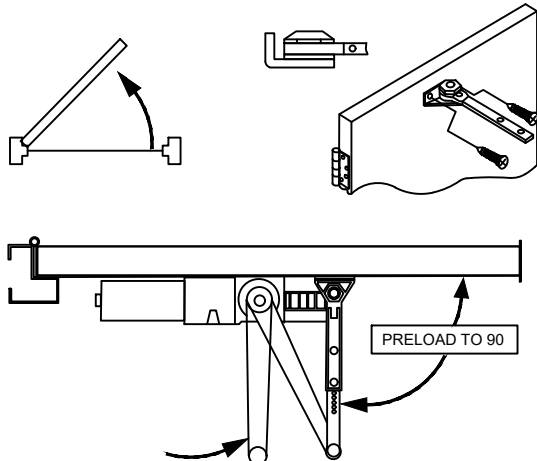

PARALLEL ARM INSTALLATION CLOSER MOUNTED ON DOOR ON PUSH SIDE



This drawing shown is RIGHT HAND DOOR, For LEFT HAND DOOR should be installed is symmetry.

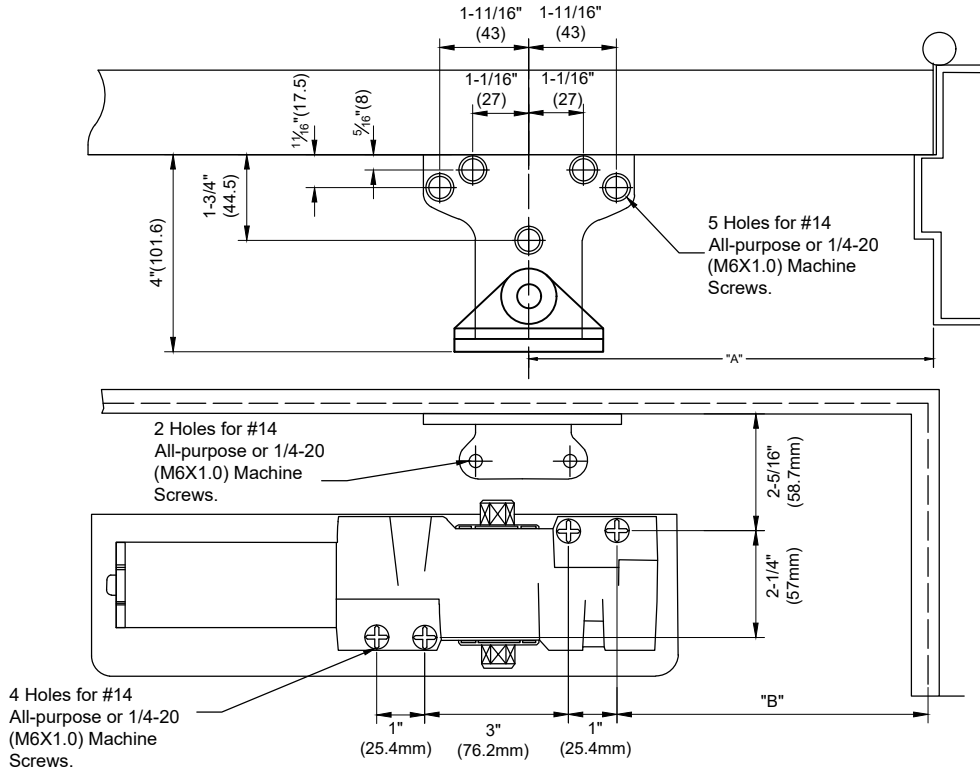

INSTALLATION DIMENSIONS

OPENNING	"A"	"B"
TO 100°	9-7/16" (240)	8-1/4" (210)
TO 130°	8-5/8" (220)	7-5/16" (185)
OVER 140°	7-7/8" (200)	6-1/2" (165)

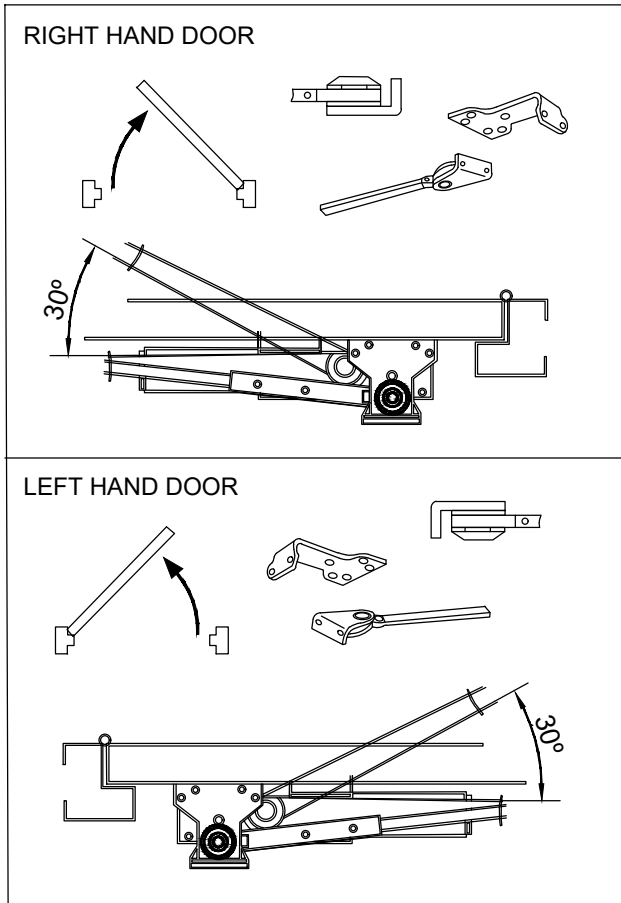

1. Before installation, turn back Check selector valve (found on the opposite side of closer from back check screw side) ALL THE WAY IN (CLOCKWISE).
2. Adjust spring power to match door width as indicated by chart on page 1.
3. Mount closer on frame as dimensions shown. Tube and toward latch. If pivot are used. locate closer and parallel bracket from CENTERLINE OF PIVOT.
4. Place open end wrench on bottom shaft and turn toward hinge jamb about 30° and then place main arm on top shaft, insert arm screw into top shaft and tighten.
5. Attach parallel bracket on frame as dimension shown.
6. Attach rod and shoe to parallel bracket shown.
7. Insert rod in forearm, and then insert main arm to closer parallel to door. Then insert forearm set screw and tighten.
(IF HOLD OPEN ARM IS USED, THE NUT IS ON THE TOP FOR RH DOOR AND BOTTOM FOR LH DOOR).

REGULATION:

A 'normal' closing time from 90° open position to door stop position is 4-6 sec's, evenly divided between main swing speed and latch swing speed. Use socket key (furnished) to adjust speed. To slow main speed of door, turn regulating screw nearest shaft clockwise. To slow latch speed, turn regulating screw nearest latch clockwise.

BACK CHECK:

To increase back-check force, turn regulating screw nearest hinge clockwise: DO NOT USE ABRUPT BACKCHECK OR EXPECT DOOR CLOSER TO ACT AS A DOOR STOP.

COVER

Place insert in proper cut-out, then push cover against door. Tighten both cover screw securely.

HOLD OPEN ADJUSTMENT (WHEN HOLD OPEN ARM IS USED)

Loose adjusting nut, open door to designed hold open position and tighten nut. Do not permit door to swing beyond open setting.