

INSTALLATION INSTRUCTION FOR F7700x120 FIRE SURFACE VERTICAL ROD EXIT DEVICE

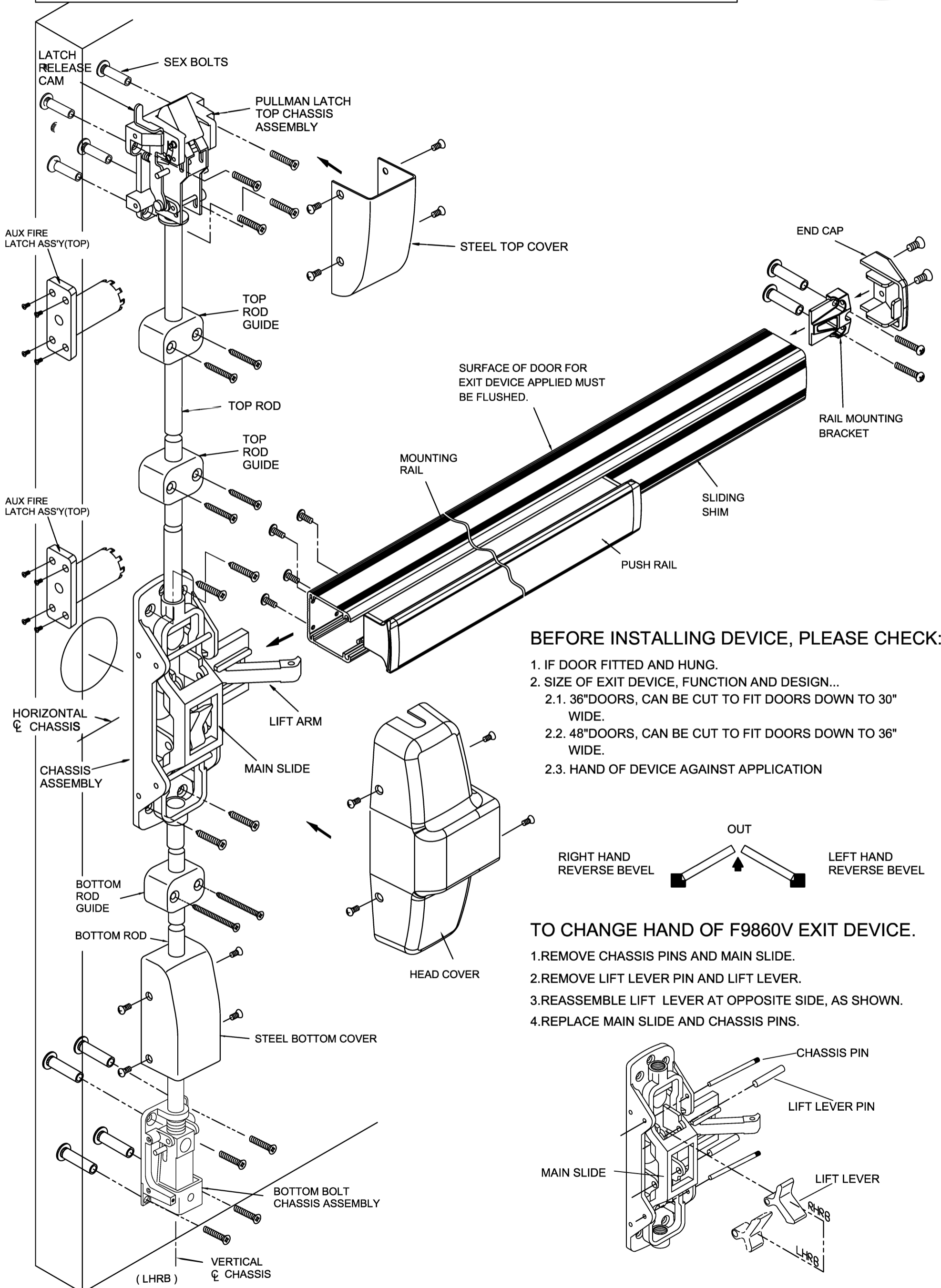

NOTE: ALL FIRE RATED APPLICATION ARE REQUIRED TO USE THE SEX BOLTS.



BEFORE INSTALLING DEVICE, PLEASE CHECK:

1. IF DOOR FITTED AND HUNG.
2. SIZE OF EXIT DEVICE, FUNCTION AND DESIGN...
 - 2.1. 36" DOORS, CAN BE CUT TO FIT DOORS DOWN TO 30" WIDE.
 - 2.2. 48" DOORS, CAN BE CUT TO FIT DOORS DOWN TO 36" WIDE.
 - 2.3. HAND OF DEVICE AGAINST APPLICATION

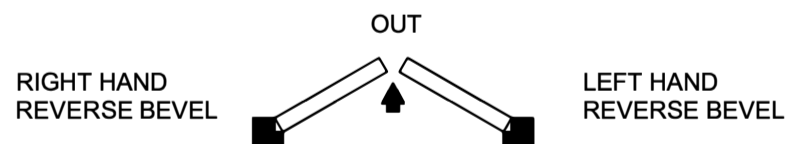

TO CHANGE HAND OF F9860V EXIT DEVICE.

1. REMOVE CHASSIS PINS AND MAIN SLIDE.
2. REMOVE LIFT LEVER PIN AND LIFT LEVER.
3. REASSEMBLE LIFT LEVER AT OPPOSITE SIDE, AS SHOWN.
4. REPLACE MAIN SLIDE AND CHASSIS PINS.

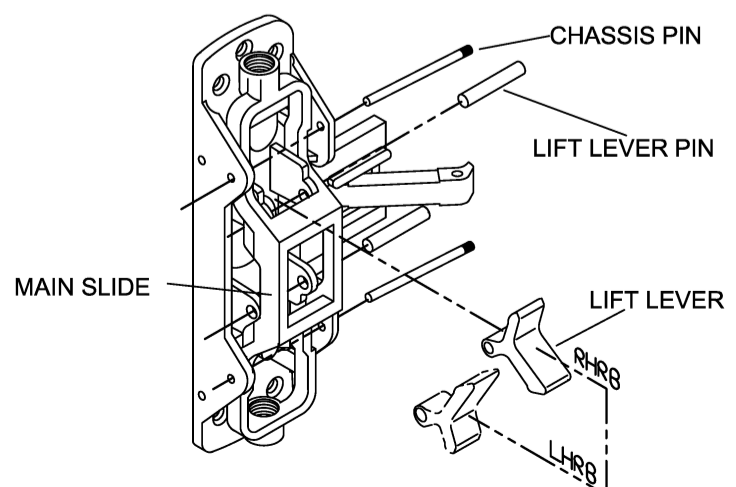

NOTE: ALL FIRE RATED APPLICATION ARE REQUIRED TO USE THE SEX BOLTS.

1. MARK VERTICAL AND HORIZONTAL REFERENCE LINE ON DOOR.

DETERMINE BACKSET TO LOCATE VERTICAL REFERENCE LINE.
 1. IF LOCK STILE IS 4-1/2" WIDE OR WIDER, BACKSET IS 2-3/4".
 2. IF LOCK STILE IS LESS THAN 4-1/2" WIDE, BACKSET IS HALF OF THE EXPOSED WIDTH OF LOCK STILE.

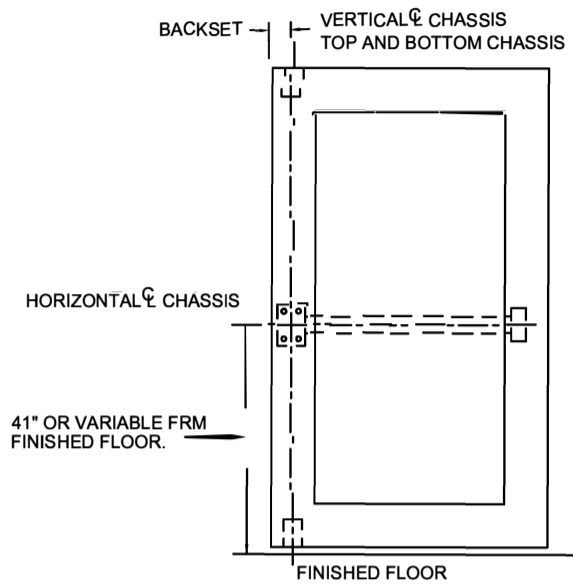

2. PREPARE DOOR

TAPE TEMPLATE ON INSIDE OF DOOR ALONG REFERENCE LINE SPOT AND DRILL HOLE.

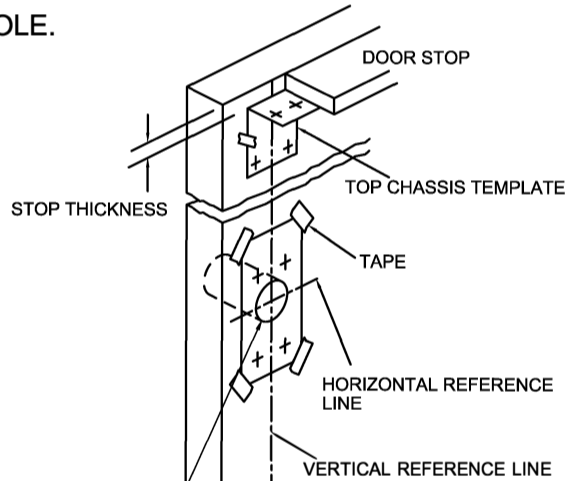

3. APPLY HARDWARE

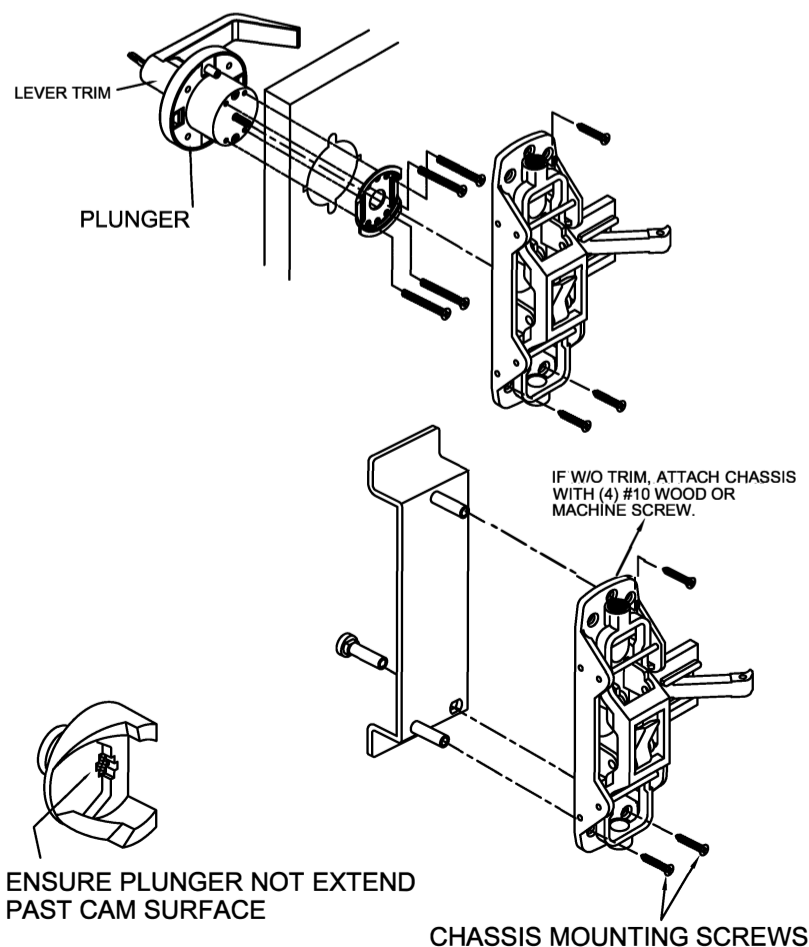

4. ATTACH TOP AND BOTTOM CHASSIS

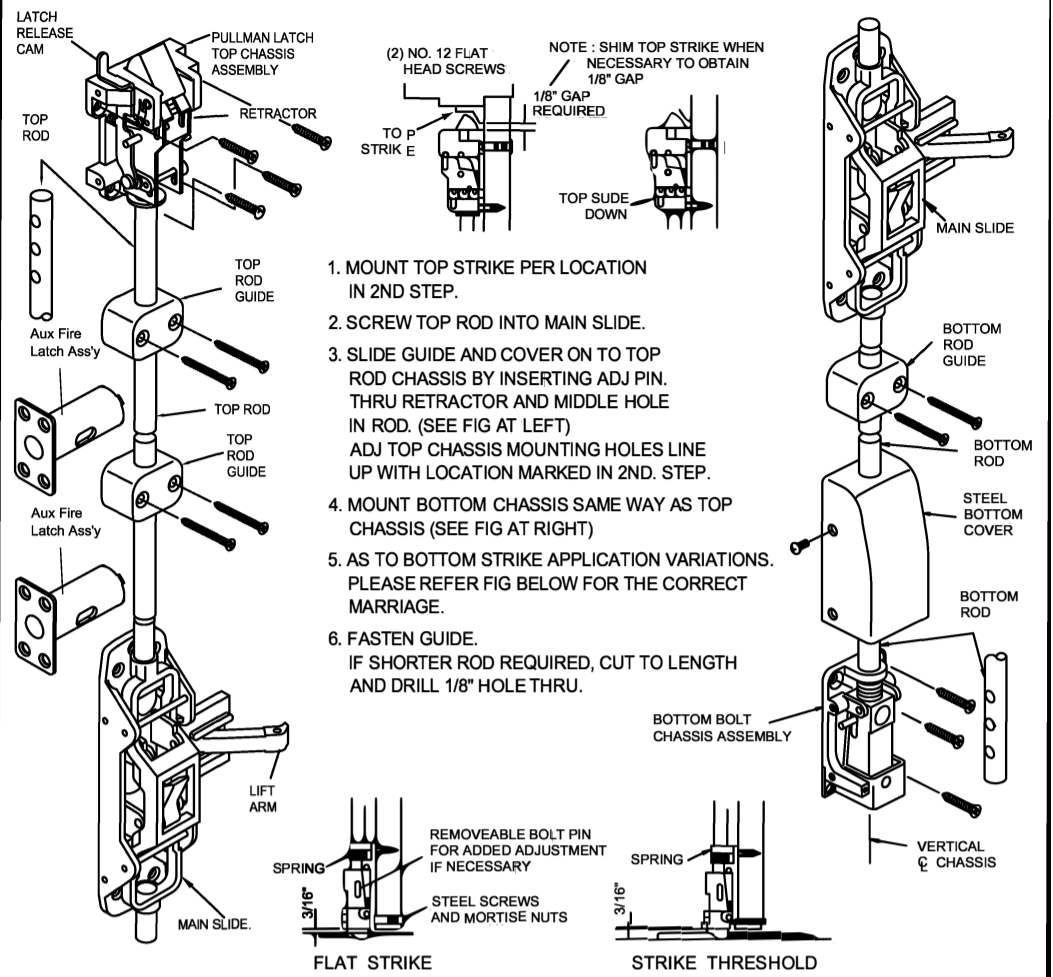

5. APPLY RAIL ASSEMBLY

- CHECK THE SIZE OF DEVICE, IF CUTTING TO LENGTH IS REQUIRED.
- DETERMINE CUT OFF LENGTH "X" BY SUBTRACTING 1-3/4" FROM "Y", MARK CUT OFF POINT ON MOUNTING RAIL.

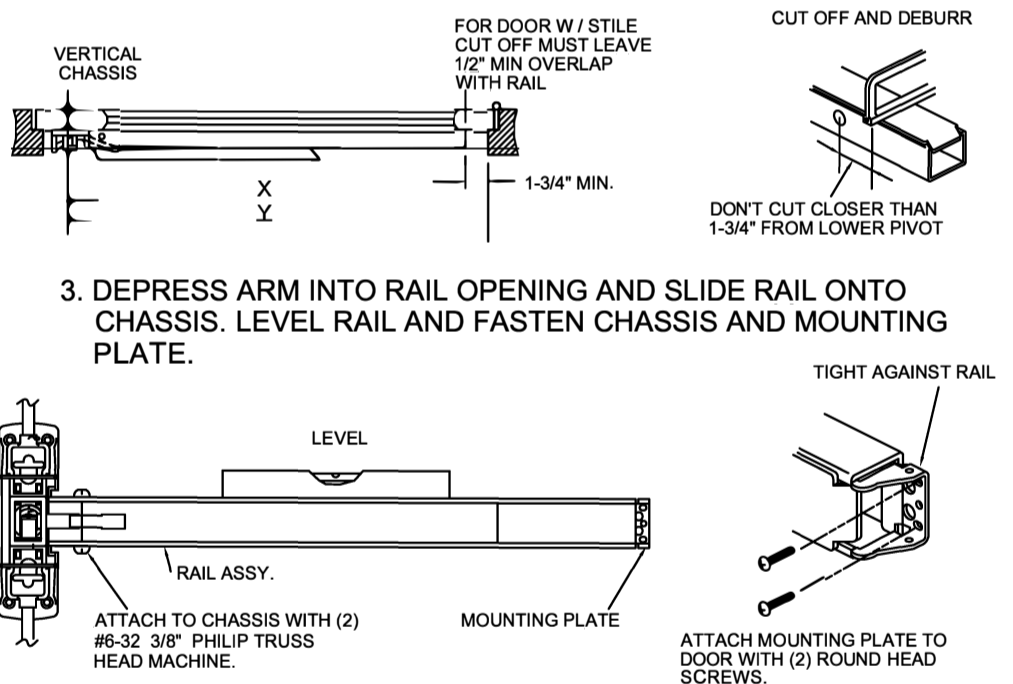

6. APPLY COVER

CHECK FINAL OPERATION OF DEVICE AND ADJUST, THEN FASTEN COVERS.

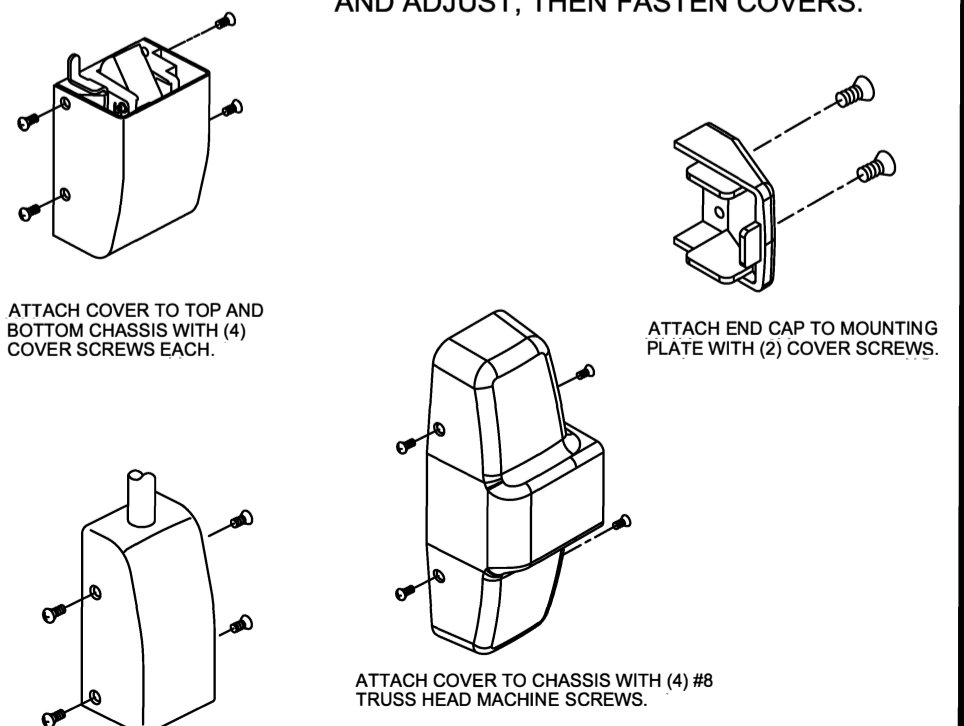

TEMPLATE

AUX FIRE LATCH ASSEMBLY F7700 & F9800 Fire Surface Vertical Rod Device for 120" Door

DESCRIPTION	QTY.
AUXILIARY FIRE LATCH ASSEMBLY	2
#6X3/6" TYPE AB FLAT HEAD SCREW	8
STRIKE HOLE PLUG	2



STRIKE HOLE PLUG

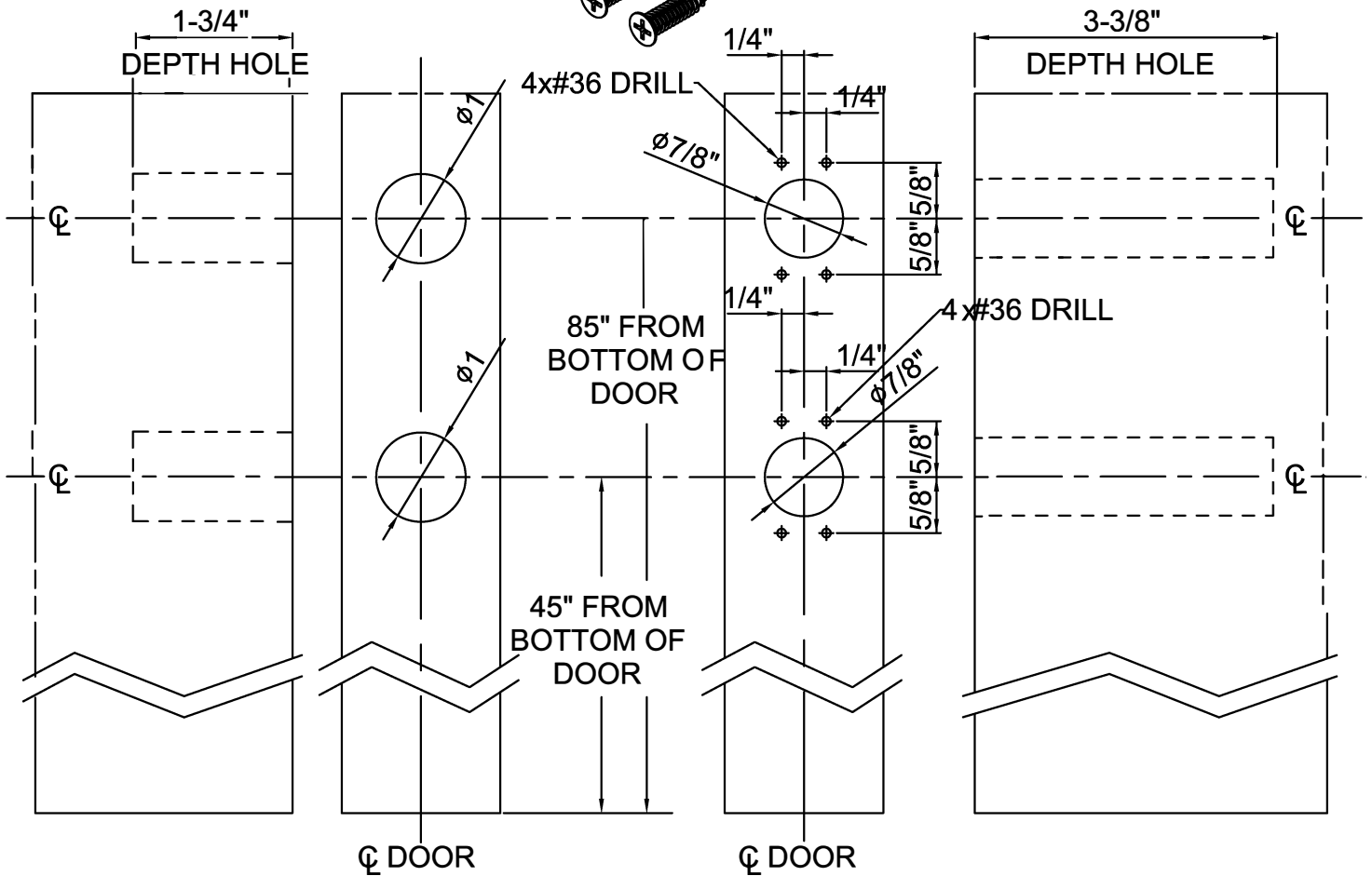
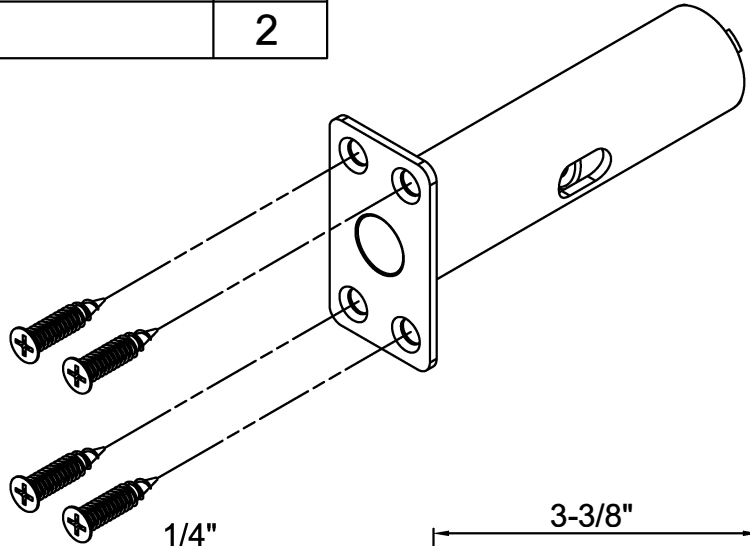

STRIKE HOLE PLUG
DOOR LEAF

AUXILIARY FIRE
LATCH ASSEMBLY
DOOR LEAF