

INSTALLATION INSTRUCTION OF ESC-45 ESCUTCHEON LEVER TRIM

PARTS NAME

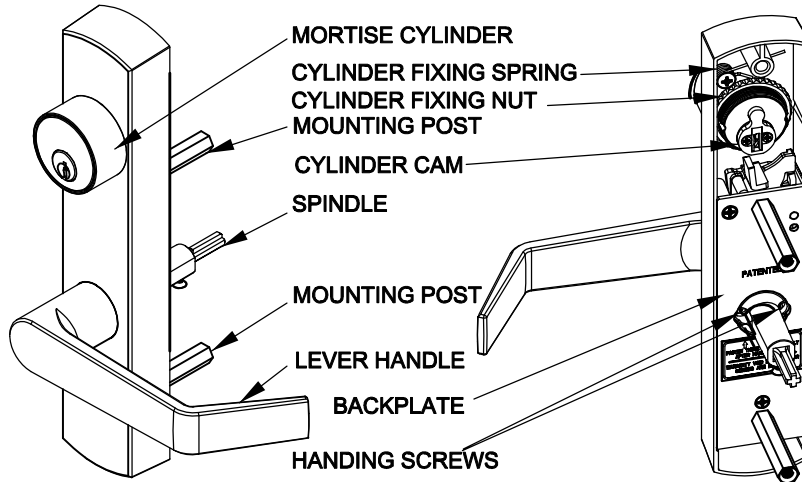

SET UP HAND OF LEVER HANDLE

1. Trim shipped with lever in neutral (non-handed) position.
2. Turn lever handle to meet door handing.(Fig.1)
3. Tighten handing screws (2), <Crosshead>.(Fig.2)

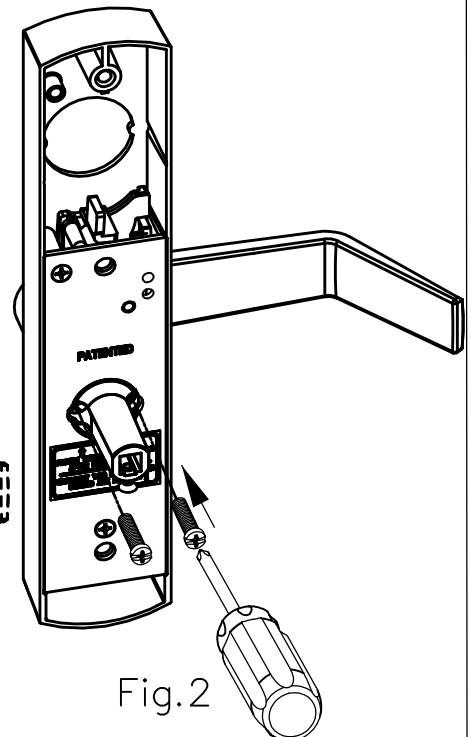
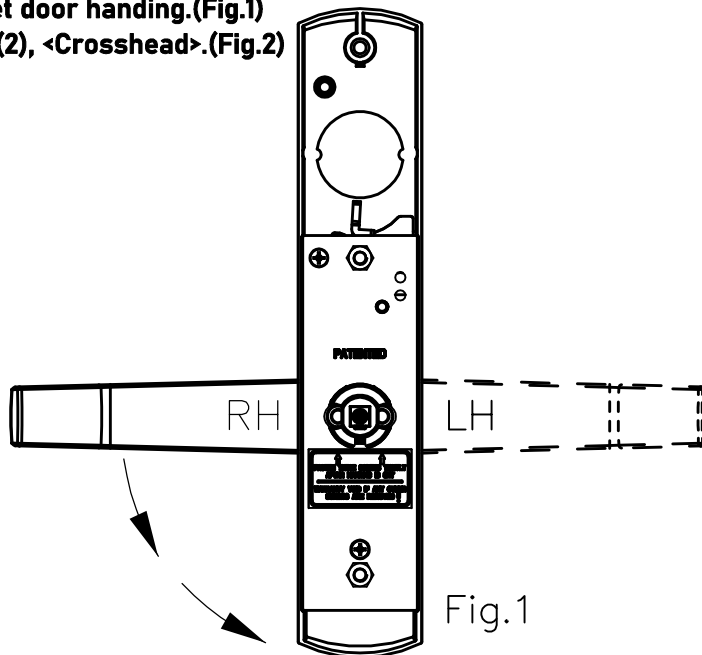

INSTALL SPINDLE & MOUNTING POSTS

1. Confirm door thickness 1-3/4"(45mm) ~ 2-3/8"(60mm), Choose Spindle hole .(Fig.3)
2. Install Spindle, tighten with M3 screw.(Fig.3)
3. Install 2Pcs mouning posts.(Fig.4)

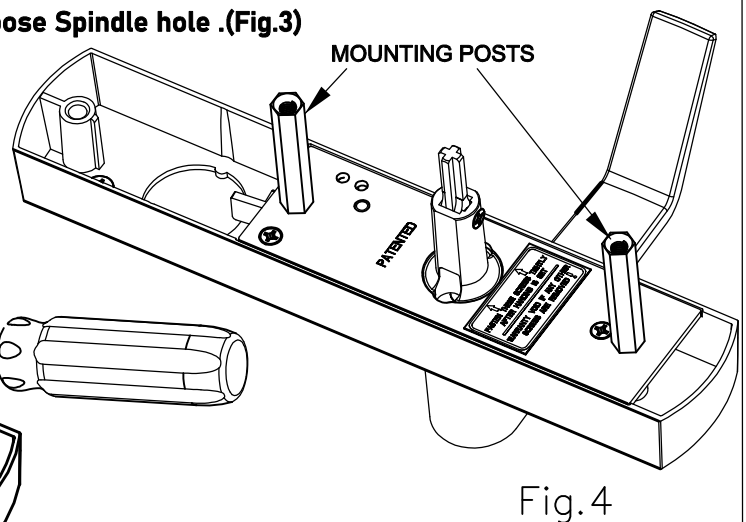
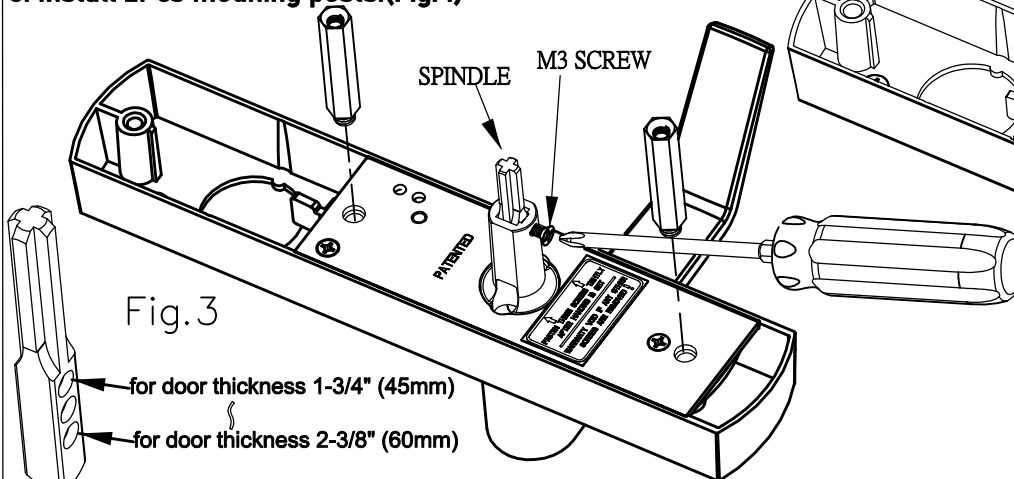

INSTALL ESCUTCHEON TRIM

1. Level ESC spindle at cross cam on back of exit device, and mounting posts at exit device mounting holes.
2. Install lever trim with exit device by fasten the screws with mouning posts.
3. Test installation by turning lever handle when lever trim is in unlock position to verify the latch can be retracted smoothly.

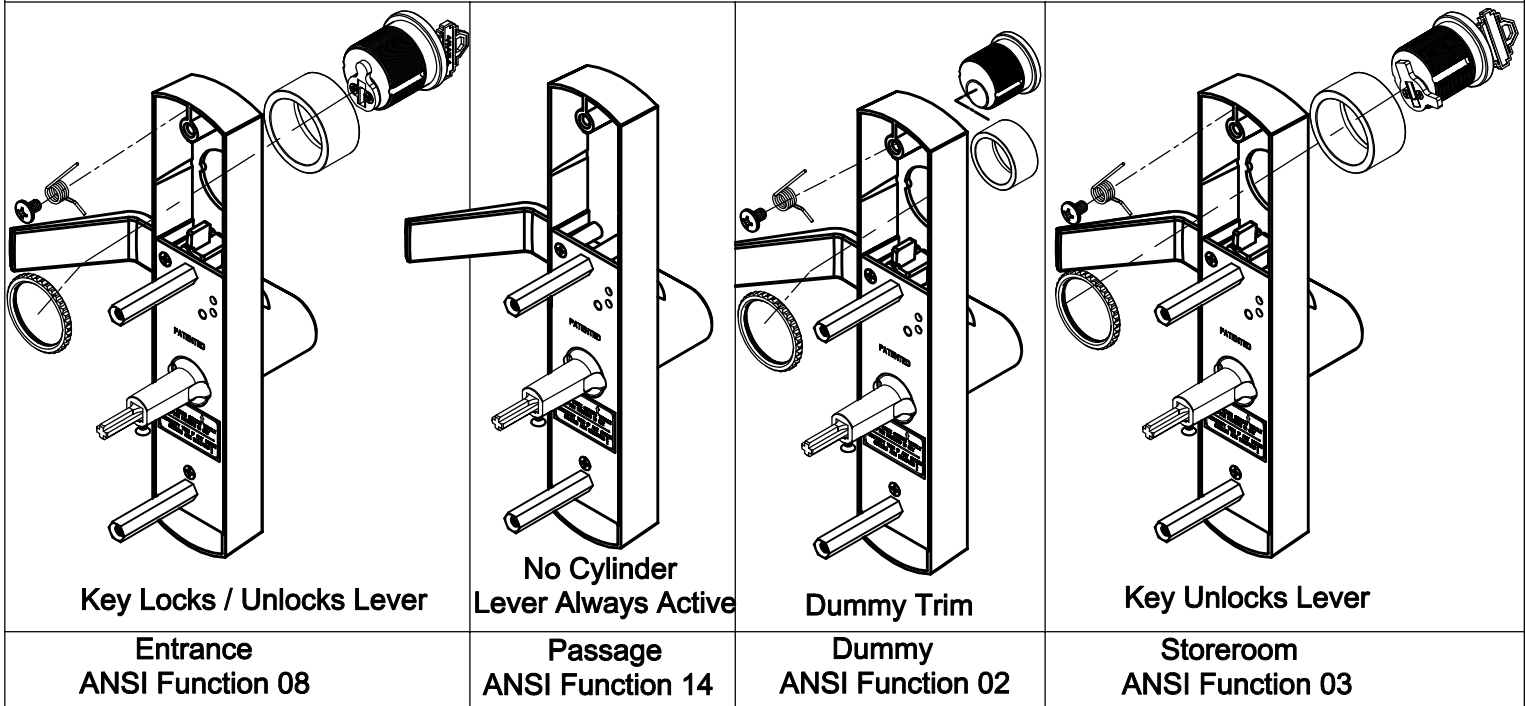
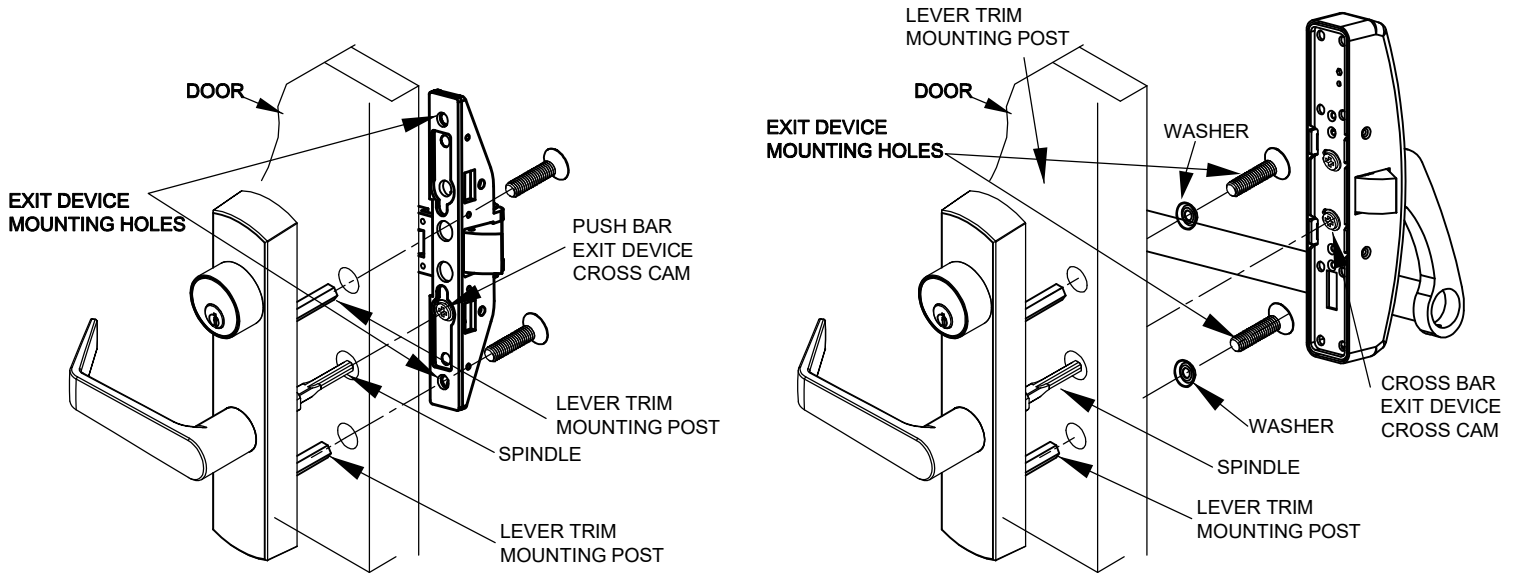

NOTE: BACKPLATE CAN NOT BE REMOVED

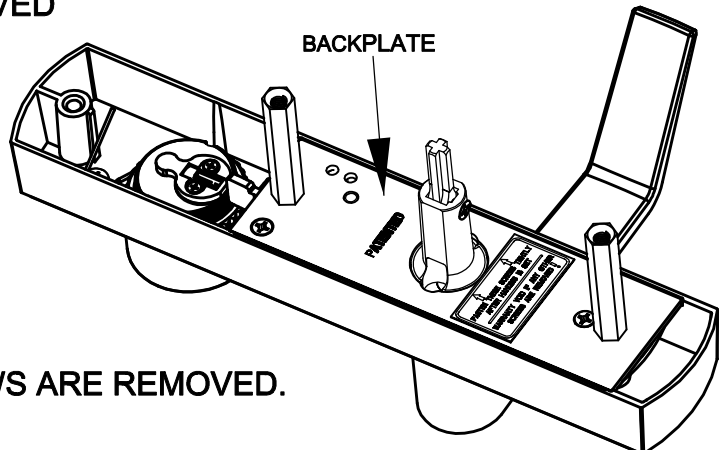

WARRANTY VOID IF BACKPLATE SCREWS ARE REMOVED.