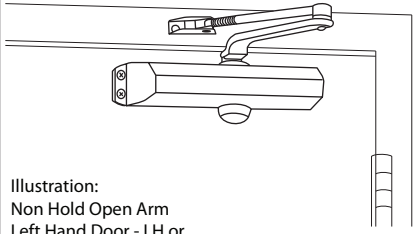
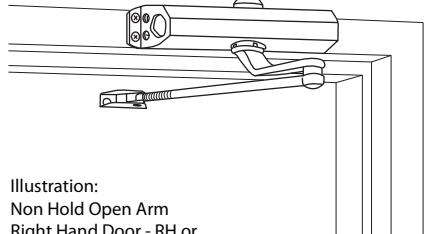
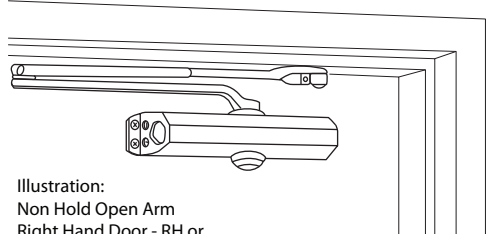

Installation Instructions

<p>REGULAR ARM INSTALLATION Closer is installed on PULL/HINGE side of door</p>  <p>Illustration: Non Hold Open Arm Left Hand Door - LH or Right Hand Reverse - RHR SEE PAGE 2</p>	<p>TOP JAMB INSTALLATION Closer is installed on frame on PUSH/STOP side of door</p>  <p>Illustration: Non Hold Open Arm Right Hand Door - RH or Left Hand Reverse - LHR SEE PAGE 3</p>	<p>PARALLEL ARM INSTALLATION Closer is installed on PUSH/STOP side of door</p>  <p>Illustration: Non Hold Open Arm Right Hand Door - RH or Left Hand Reverse - LHR SEE PAGE 4</p>
-----------------------------------------------------------------------------------------------------------------------------------------------------------------------------------------------------------------------------------------------------------------------------------------------	----------------------------------------------------------------------------------------------------------------------------------------------------------------------------------------------------------------------------------------------------------------------------------------------------	-------------------------------------------------------------------------------------------------------------------------------------------------------------------------------------------------------------------------------------------------------------------------------------------------

CLOSER ADJUSTMENT

CLOSING CYCLE

NOTE: Closing arcs ("CLOSE" and "LATCH") are controlled by two (2) separate speed valve adjuster. Adjust the CLOSING speed first, then adjust the LATCHING speed.

- "CLOSING" speed adjustment is accomplished by full rotations of the speed valve adjuster.
 - Turn the speed valve screw CLOCKWISE for a slower close arc closing speed.
 - Turn the speed valve screw COUNTER-CLOCKWISE for a faster close arc closing speed.
- "LATCH" speed adjustment is accomplished by full rotations of the speed adjuster valve.
 - Turn the speed valve screw CLOCKWISE for a slower latch arc closing speed.
 - Turn the speed valve screw COUNTER-CLOCKWISE for a faster latch arc closing speed.

CAUTION!! Do not turn speed adjuster valve more than two (2) full turns counter-clockwise from its factory default position, as the two speed valve adjusters could become dislodge from the door closer body, resulting in the loss of internal fluid and failure of the device.

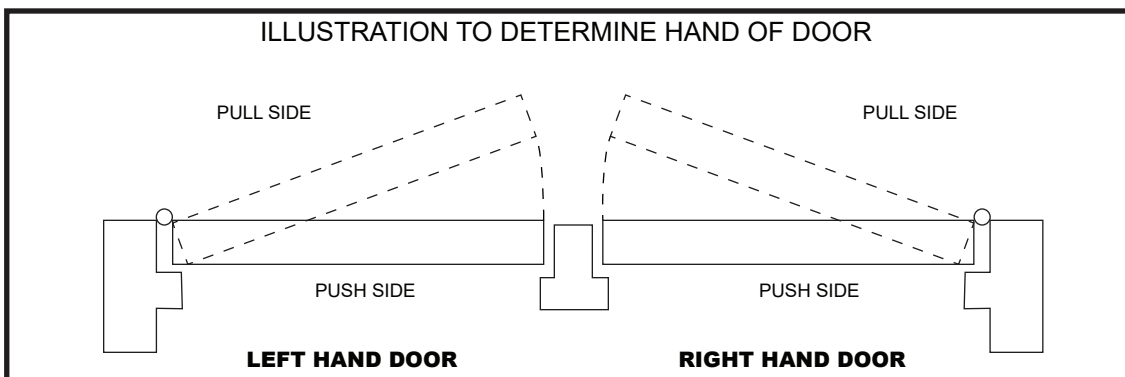
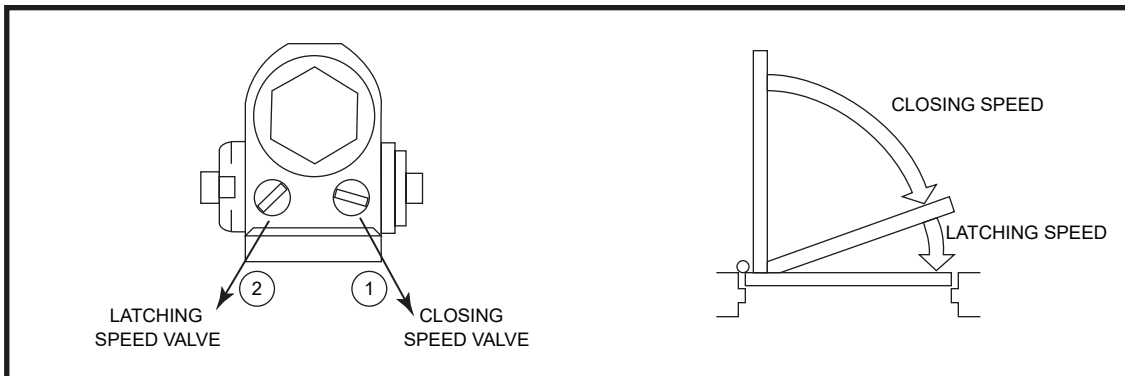

Installation Instructions for REGULAR ARM (PULL SIDE) Mounting

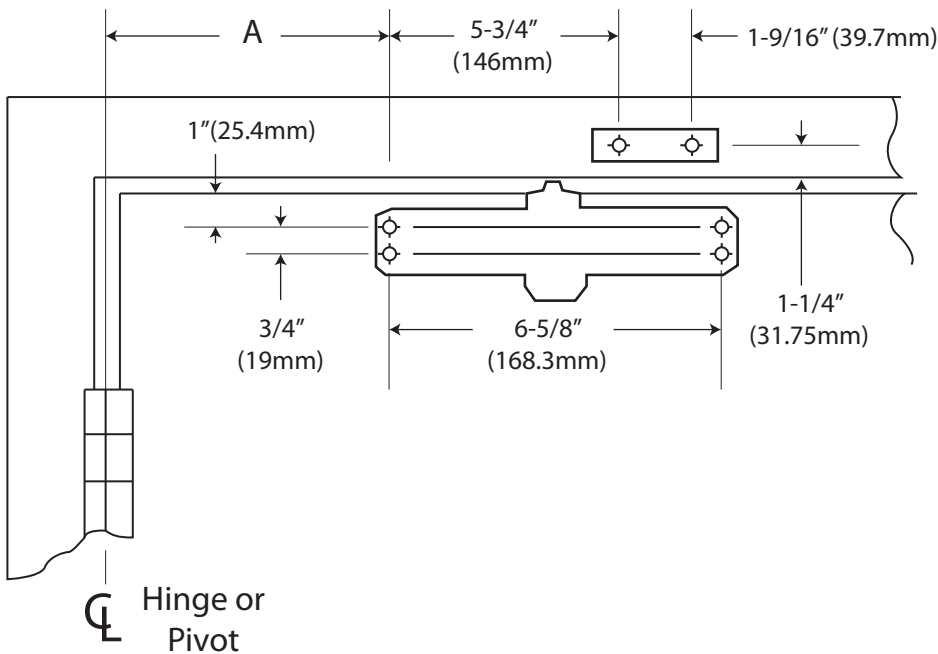

SIZE: 2
Model: 420-P

OPENING	DIM. A
To 120°	3-3/4" (95.25mm)
120°-180°	2-9/16" (65mm)

- Right hand door shown
- Left hand door opposite
- Dimensions are in inches
- Do not scale drawing

INSTALLATION INSTRUCTIONS

1. Select Door opening angle and use dimensions shown above. Mark four(4) on door for door closer and two(2) holes on frame for arm shoe.
2. Drill pilot holes on door and frame, #14 all-purpose screws or drill and tap for 1/4-20 machine screws.
3. Install forearm/arm shoe assembly to frame using screws provided.
4. Mount closer on door using screws provided. SPEED ADJUSTER VALVE MUST BE POSITIONED TOWARDS HINGE EDGE.
5. Install main arm to top pinion shaft, perpendicular to door as shown below, secure tightly with arm screw/washer assembly provided.
6. Adjust length of forearm so that forearm is perpendicular to frame when assembled or preloaded main arm (Illustration below). Secure forearm to main arm with screw/washer assembly provided.
7. Snap pinion cap over shaft at bottom of closer. 8. Adjust closing speed of door, following instructions as shown in page 1.

OPENING CYCLE

NOTE: These instructions apply only to closers equipped with backcheck.
 - To increase backcheck intensity, turn valve marked "BC" clockwise
 - To decrease backcheck intensity, turn valve marked "BC" counter-clockwise.

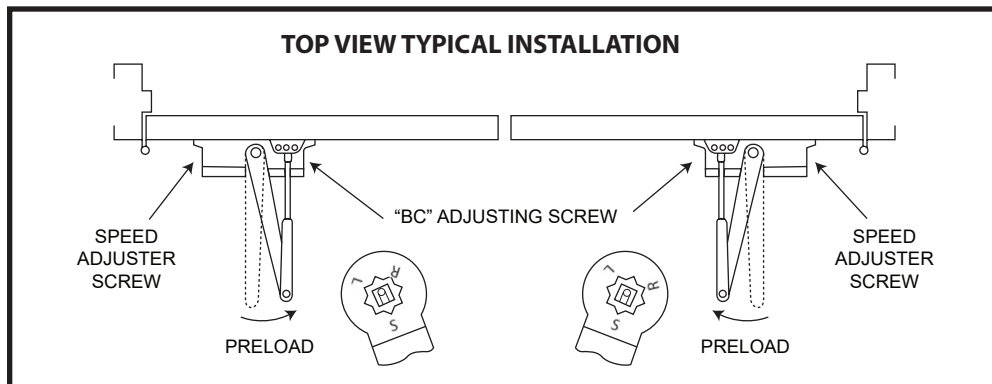
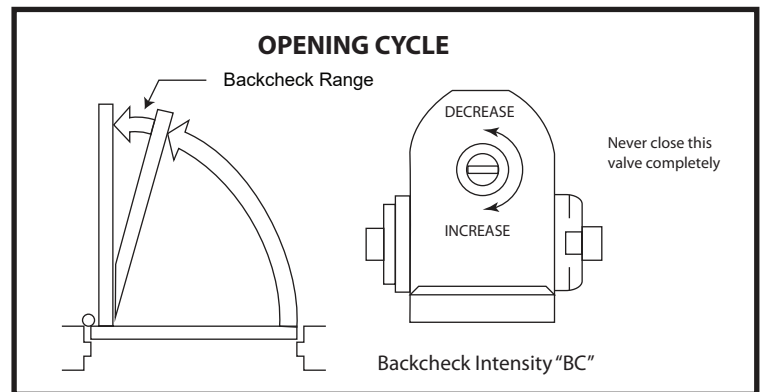



Series: 400
 Model: 420-P
 Size: 2

Installation Instructions for TOP JAMB (PUSH SIDE) Mounting

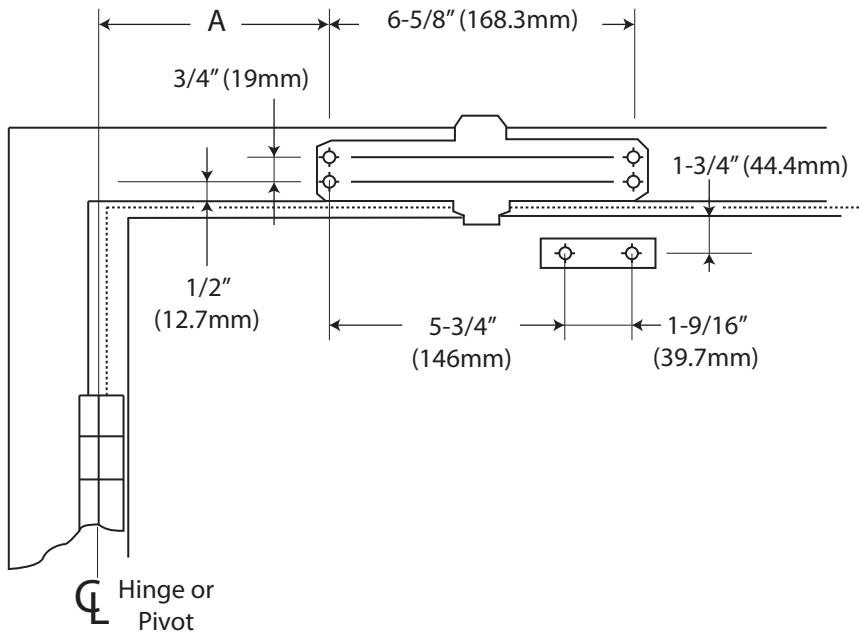

SIZE: 2
 Model: 420-P

OPENING	DIM. A
To 120°	3-3/4" (95.25mm)
120°-180°	2-9/16" (65mm)

- Right hand door shown
- Left hand door opposite
- Dimensions are in inches
- Do not scale drawing

INSTALLATION INSTRUCTIONS

1. Select Door opening angle and use dimensions shown above. Mark four(4) on door for door closer and two(2) holes on frame for arm shoe.
2. Drill pilot holes on door and frame , #14 all- purpose screws or drill and tap for 1/4-20 machine screws.
3. Install forearm/arm shoe assembly to frame using screws provided.
4. Mount closer on door using screws provided. SPEED ADJUSTER VALVE MUST BE POSITIONED TOWARDS HINGE EDGE.
5. Install main arm to top pinion shaft, perpendicular to door as shown below, secure tightly with arm screw/washer assembly provided.
6. Adjust length of forearm so that forearm is perpendicular to frame when assembled or preloaded main arm (Illustration below). Secure forearm to main arm with screw/washer assembly provided.
7. Snap pinion cap over shaft at bottom of closer.8. Adjust closing speed of door, following instructions as shown in page 1.

OPENING CYCLE

NOTE: These instructions apply only to closers equipped with backcheck.
 - To increase backcheck intensity, turn valve marked "BC" clockwise
 - To decrease backcheck intensity, turn valve marked "BC" counter-clockwise.

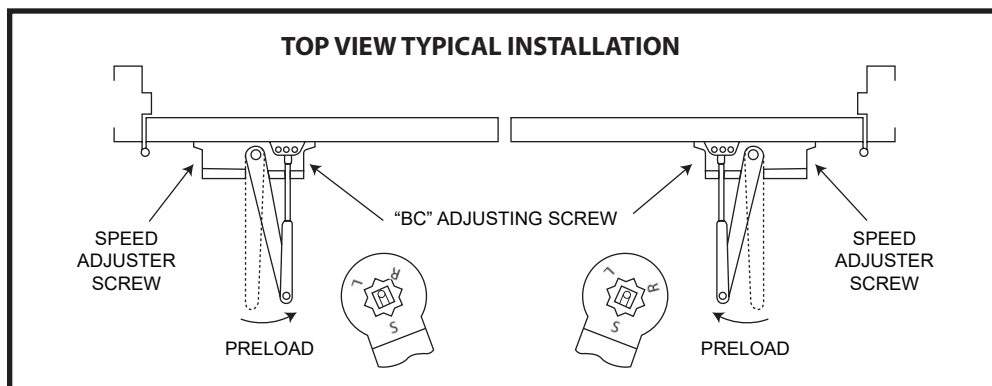
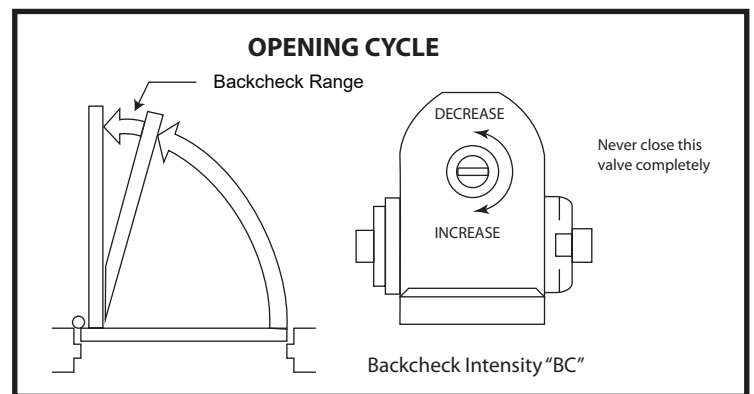

Installation Instructions for Parallel Arm (PUSH SIDE) Mounting

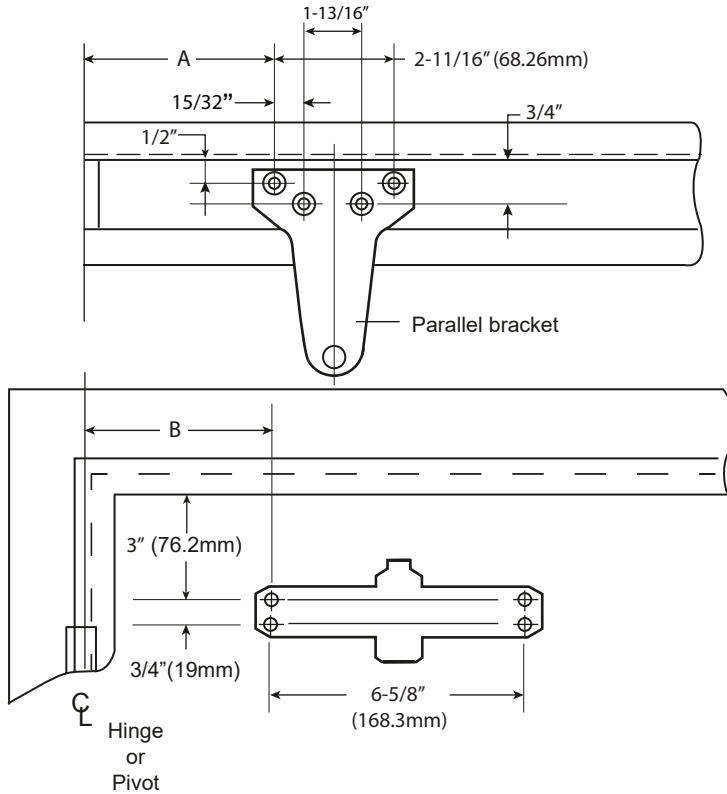

SIZE: 2
Model: 420-P

OPENING	DIM. A	DIM. B
To 120°	5-7/8" (149.2mm)	4-11/16" (119mm)
120°-180°	4-11/16" (119mm)	3-1/2" (88.9mm)

- Right hand door shown
- Left hand door opposite
- Dimensions are in inches
- Do not scale drawing

INSTALLATION INSTRUCTIONS

1. Select door opening angle and use dimensions shown above, mark four (4) holes on door for door closer and three (3) holes underside of frame for parallel bracket.
2. Drill pilot holes in door and frame for #14 all-purpose screws or drill and tap for 1/4-20 machine screws.
3. Mount closer on door using screws provided. SPEED ADJUSTER VALVE MUST BE POSITIONED AWAY FROM HINGE EDGE.
4. Install Parallel Arm Bracket to frame using screws.
5. Using a wrench on the square shaft at bottom of closer, rotate shaft approximately 45° toward hinge edge of door. Hold and place main arm of shaft on top of closer at proper index mark as illustrated. FOR LEFT HAND DOOR "L" (illustration "A") FOR RIGHT HAND DOOR "R" (illustration "B"). Tighten arm screw with lockwasher securely.
6. Remove arm shoe from forearm and discard. Install ROD end of forearm to bracket using screw/washer assembly provided.
7. Adjust length of adjustable forearm so that adjustable forearm is parallel to frame.
8. Adjust closing speed of door, following instructions as shown in Page 1.

OPEN CYCLE

NOTE: These instructions apply to closers equipped with backcheck

- To increase backcheck intensity, turn valve marked "BC" clockwise.
- To decrease backcheck intensity, turn valve marked "BC" counter-clockwise

