

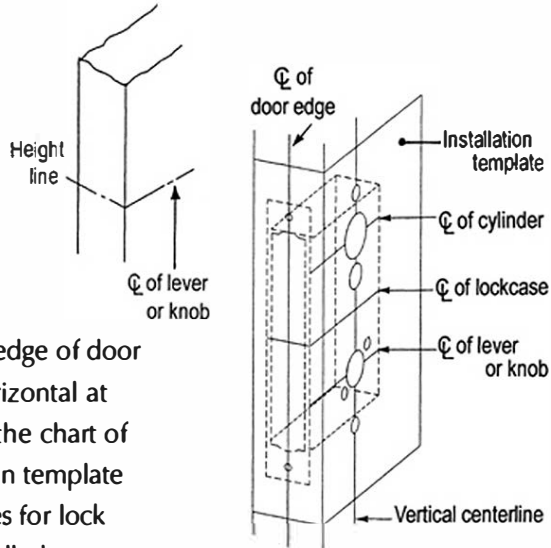

SC Series(SC8480) Heavy Duty Mortise Lock (Escutcheon Type) Installation Instructions

A. Door Preparation

1. Measure desired height from finished floor, mark a horizontal line on door and door edge.



2. Align template on edge of door with applicable horizontal at height line. Check the chart of drilling trim holes on template and mark only holes for lock function being installed.

3. Mortise door edge according to measurements of installation template and drill proper holes for trims.

4. Recess for face plate, the dimension is L 8-1/32" x W 1-5/16" x D 7/32".

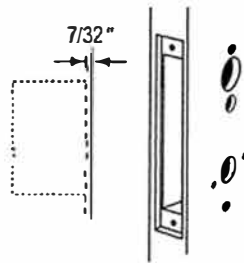

B. Strike Installation

1. Align strike template on jamb. Be sure to keep 3/8" distance between lock centerline and strike centerline. Bore 1" diameter holes into door edge, 1-1/8" deep. Recess 5/32" for flush fit of strike and dust box.

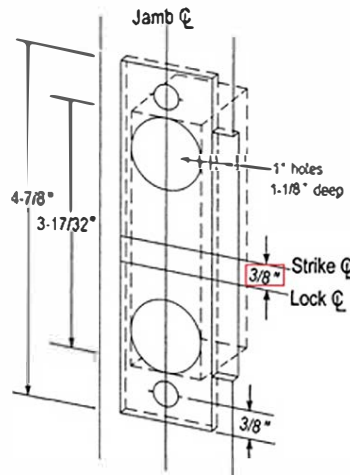

2. Mortise jamb according to measurement of strike template. Then fit strike and dust box into frame and secure into place with supplied screws.

C. Install Lock Case

- A) Make sure lock hand to match door hand, use the following diagram to determine the hand of door.

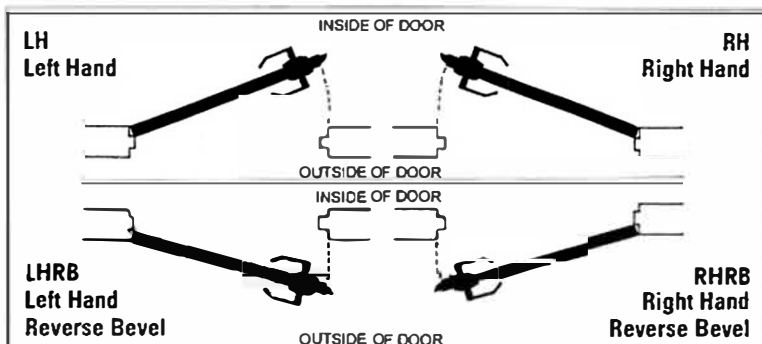

B) Instructions for changing lock hand :

1. Change latchbolt handing

If the hand of latchbolt doesn't match door hand, remove fixing screw and pull latchbolt out from lock case, then turn complete unit having the bevel of latchbolt to reverse door handing. Position latchbolt back and fasten it.

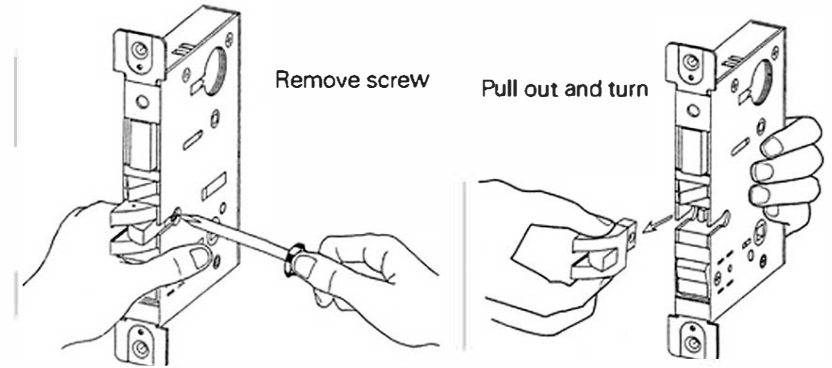

2. Set outside hand of lock case

There are two SET SCREWS located at the bottom of the HUB, one on each side. Remove the SET SCREW on the side facing the secured side (outside or key side), and leave the one facing the interior side (inside).

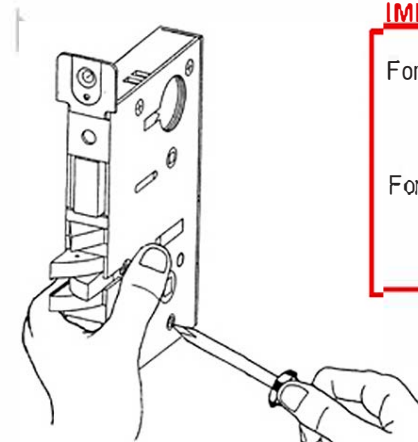

IMPORTANT

For SC8466 (Store Lock) F14 and SC8010 (Passage) F01: SKIP THIS STEP.

For SC8082 (Institution) F30: REMOVE SET SCREW ON BOTH SIDES.

- C) Check the hub of the lock if it is seated squarely with respect to the body of the lock. Either arrow 1 or 2 on either side should point directly to the set screw.

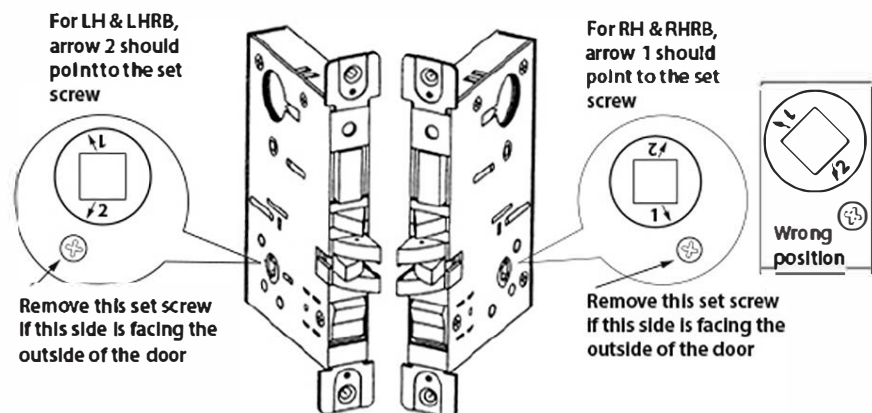

If the set screw is accidentally removed, follow procedures below to put it back.

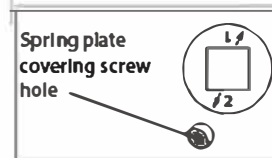

- 1 Pick the spring plate to push it aside and at the same time 2 turn and hold the hub by using the spindle a couple of degrees until the spring plate is out of the way. Don't let go of the hub while 3 inserting the screw until it is fully fastened.

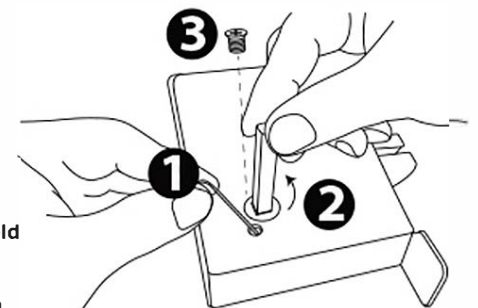

- D) Insert lock case into mortise cut – out and fasten screws to door.

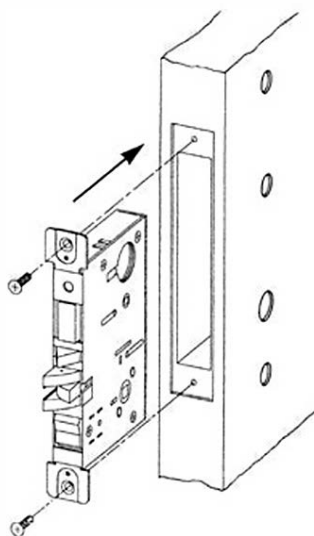

D. Install Outside Trim & Cylinder

1. Insert spindle into hub of spring cage on outside trim.
2. Make sure the direction of outside lever to be installed, then place the reversible spring cage into ferrules with arrow pointing in direction of lever rotation and fasten with screws.

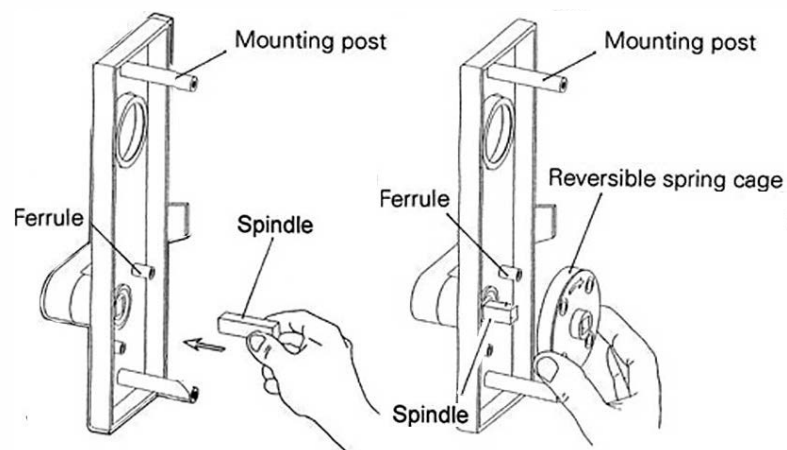

3. Install outside trim with mounting posts through door and position spindle into hub of the lock case.
4. Loosen the cylinder retaining screw to allow the mortise cylinder to be threaded into lock case by inserting a screw driver in the hole on the mortise lock body.
5. Screw the mortise cylinder through the outside trim into cylinder hole in the lock case.
6. Tighten retaining screw against cylinder by turning screw clockwise

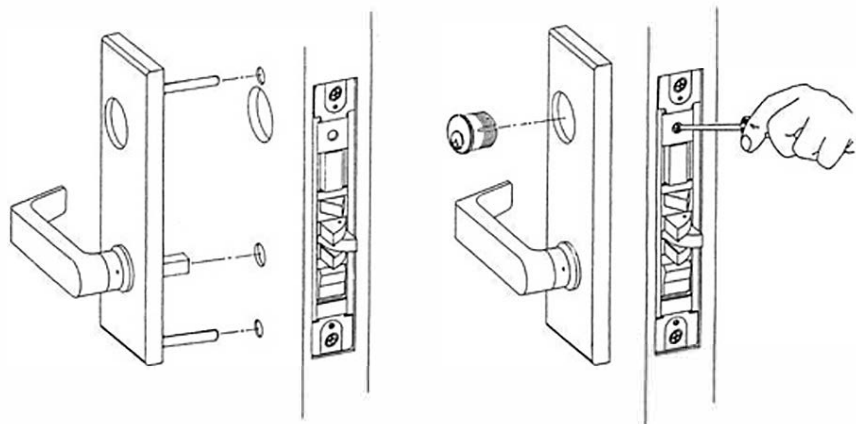

E. Install Inside Trim

1. Disassemble inside trim assembly by spanner wrench first before next step.
2. Insert spindle into hub of the lock case and turn it to double check if latchbolt can be retracted. Then screw connecting pin through the spindle.

3. Place reversible spring cage into ferrules on mounting plate with arrow pointing in direction of lever rotation, fasten it with screws.
4. Install mounting plate onto spindle. Tighten with provided screws.
5. Cap inside escutcheon over mounting plate and insert turnpiece spindle into its hub. Make turnpiece in vertical when deadbolt is projected.

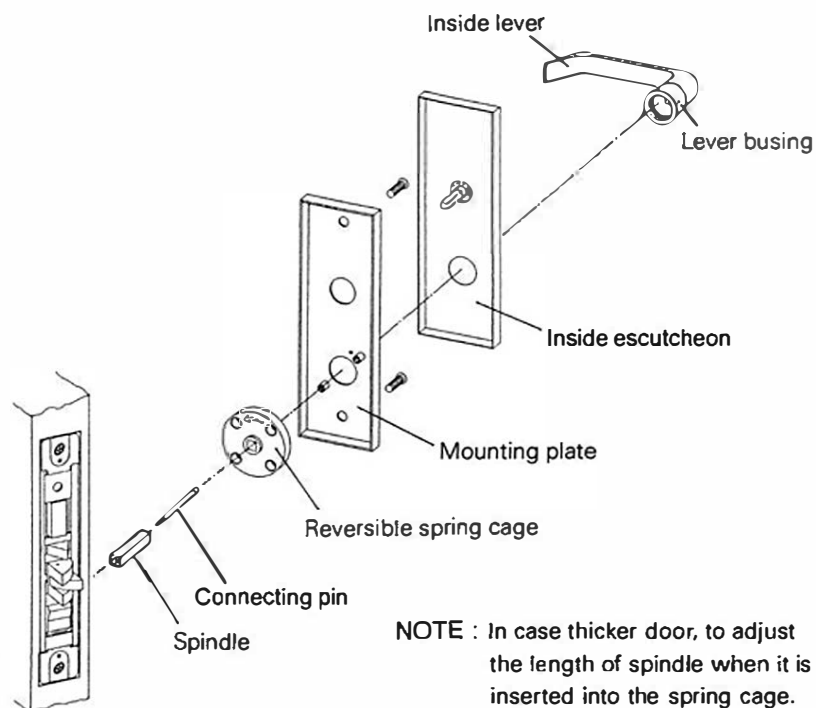

6. Screw inside lever into position and tighten lever busing with spanner wrench.

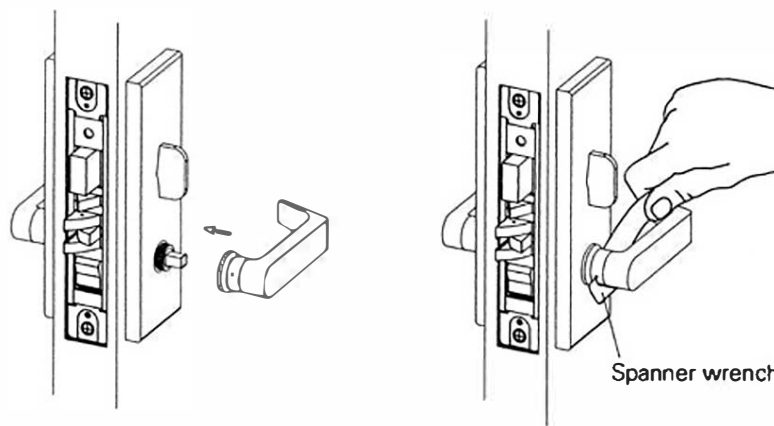

F. Install Armor Face Plate

Install face plate onto lock case front and fasten with supplied screws.

