

HINGE OR PIVOT

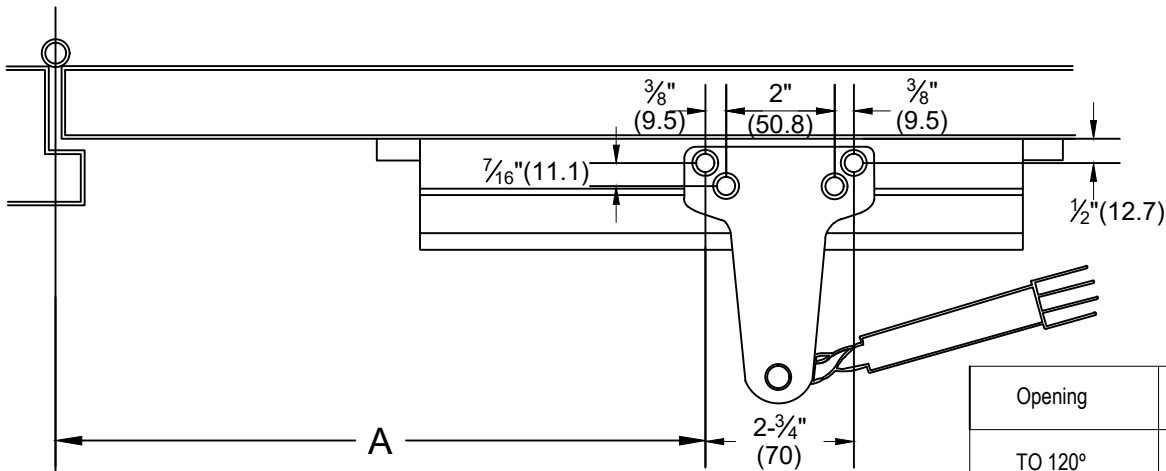

Opening	Dimension "A"	Dimension "B"
TO 120°	9-1/2"(241mm)	3-3/4"(95mm)
TO 180°	7"(178mm)	1-1/4"(32mm)

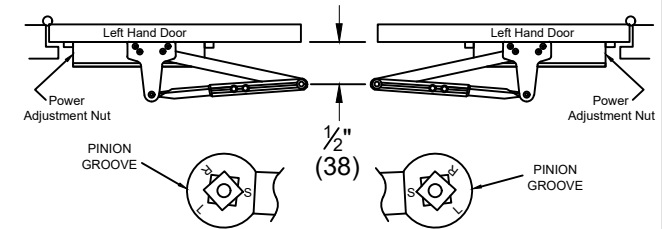
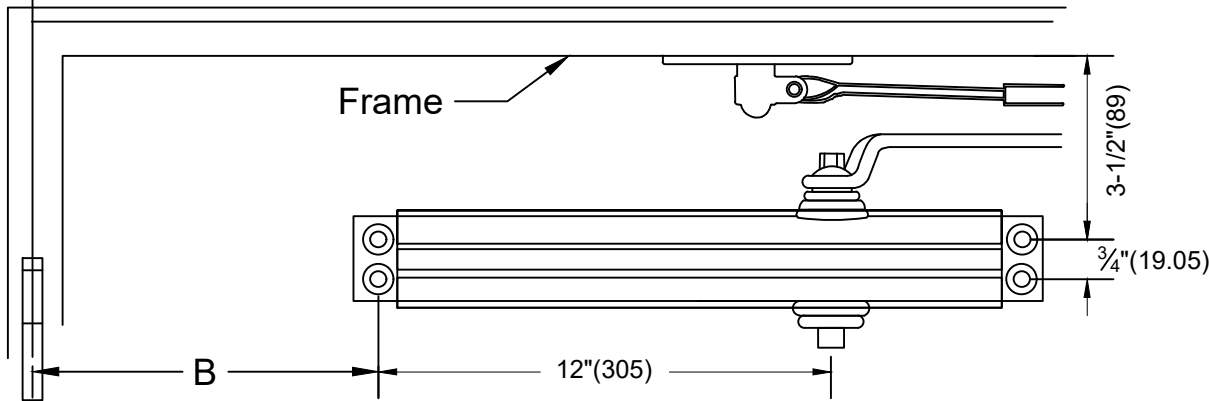

Preparation for Fasteners		
Fasteners	Door or frame	Drill-Sizes
Self Drilling/Tapping Machine Screw	Hollow Metal or Aluminum	No drill required
	Wood (see note)	3/16" pilot hole
1/4"-20 Machine Screw	Hollow Metal	Drill # 7 (0.201" dia.) & Tap 1/4"-20
Self Drilling/Tapping Machine Screw	Hollow Metal or Aluminum	5/32" drill closer side & 3/8" drill opposite side
	Wood Screw	3/16" pilot hole
Wood Screw	Wood	3/16" pilot hole

NOTE: Wood doors/frames must have a pilot hole drilled when using Self Drilling/Tapping screws.

The illustration and technical description in this cut sheet is current as of the date in version date on the right. Cal-Royal Product reserves the right to, and may, on occasions, make changes and/or improvements in designs and dimensions without prior notice.



6605 Flotilla Street
 City of Commerce
 CA 90040 USA
 Tel:# (323) 888-6601
 FAX:# (323) 888-6699
 WEB SITE:
 CAL-ROYAL.COM
 Email: sales@cal-royal.com

ITEM NO.	DESCRIPTION :
CR801	TEMPLATE OF CR801 Parallel Arm Installation

NOT TO SCALE
 PAGE 1 OF 1

UNIT
 PRIMARY DIMENSION SHOWN IN INCHES, DIMENSIONS IN () ARE MM

Prepared By:
 BBT / ADG / CVL

DATE
 04/18/2022

DWG. NO.
 DCT1024
 REV - - -